

YAMAHA

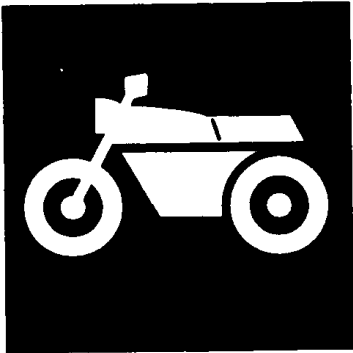

**PARTS
CATALOGUE**

TDM850'98(4TX3) EUROPE

TDM850'98(5AR2) SWITZERLAND, AUSTRIA

184TX-300E1

YAMAHA
GENUINE
Parts & Accessories



FOREWORD

This Parts Catalogue is related to the parts for the model(s) in the below frame. When you are ordering replacement parts, please refer to this Parts Catalogue and quote both part numbers and part names correctly.

TDM850'98(4TX3/5AR2)

1. Modifications or additions which have been made after issue of the Parts Catalogue will be announced in the Yamaha Parts News.

It is advisable that you make necessary corrections to the Parts Catalogue according to the Yamaha Parts News.

2. Abbreviations

The Following abbreviations are used in this Parts Catalogue.

"UR" Use specified parts number.

"UN" Use as many as needed.

"AP" Alternate Parts

"UM" Local Made (Parts need to be ordered locally)

"F#" Frame No. (Applicable machine No.)

3. Parts, which are to be supplied in an assembly, are listed with a dot(.) in front of the part name as shown below.

EXAMPLE

CARBURETOR ASSY

.JET, PILOT

.NOZZLE, MAIN

4. Number of component for assembly

The numeral appearing to the right of each component part indicates the quantity of parts for each assembly unit.

EXAMPLE

PART NO.	DESCRIPTION	Q'TY	REMARKS
2F5-83310-60	FRONT FLASHER LIGHT ASSY	2	
115-83311-60	.BULB (6V-18W)	1	
1M1-83309-60	.REFLECTOR	1	

5. Applicable colors of graphics are represented in the "REMARKS" as shown below.

PART NO.	DESCRIPTION	Q'TY	REMARKS
2N4-24110-00-X5	.FUEL TANK COMP.	2	MXR
3J1-24240-10	.GRAPHIC, FUEL TANK	1	for MXR

6. Applicable Serial No.

① Engine Serial No.

② Frame Serial No.

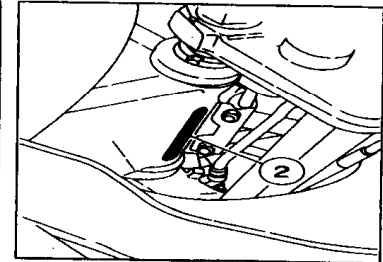
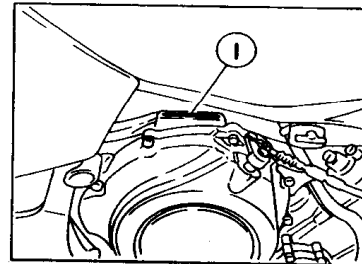

7. Note that the illustrations for reference in finding parts numbers, not to be used for assembling. When assembling, please use the applicable service manual.

8. The asterisk (*) before a reference number indicates modification items after the first edition.

MODEL LABEL

(1) A label called "Model Label" is affixed in the location as indicated in (3) below.
When using this parts catalogue, please be sure to cross-refer the "model code - production code No." in the catalogue to the "model code - production code No." indicated on the Model Label affixed onto the product concerned.

(2) "Model Label" Indication

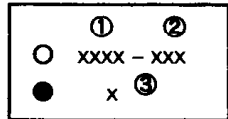

① Model Type Code
② Production Code No.
③ Colouring Type

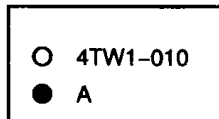

(3) Model Label Affixing Location

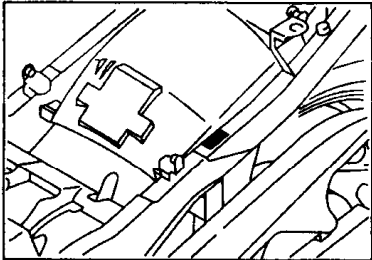

(4) Model Code - Production Code Number of Model Listed in This Parts Catalog

Model Code	Production Code No.	Country (destination)	Model Code	Production Code No.	Country (destination)
4TX3	020	BELGIUM			
	040	DENMARK			
	060	FINLAND			
	070	ENGLAND			
	080	GREECE			
	090	ITALY			
	100	HOLLAND			
	110	NORWAY			
	120	PORTUGAL			
	130	SWEDEN			
5AR2	010	SWITZERLAND			
	020	AUSTRIA			

(5) Colouring Information

Colouring type code	Colour code	Colour Name	Abbreviation
A	004B	BLACK 2	BL2
B	0625 *	DEEP REDDISH YELLOW COCKTAIL 1	DRYC1
D	0564	DEEP PURPLISH BLUE METALLIC C	DPBMC

CONTENTS

ENGINE

CYLINDER HEAD	B2
CYLINDER	B3
CRANKSHAFT. PISTON	B4
VALVE	B6
CAMSHAFT. CHAIN	B8
WATER PUMP	B9
RADIATOR. HOSE	B10
OIL PUMP	B12
INTAKE	C2
CARBURETOR	C4
EXHAUST	C7
CRANKCASE	C8
CRANKCASE COVER 1	C10
STARTER CLUTCH	C12
CLUTCH	C13
TRANSMISSION	C15
SHIFT CAM. FORK	D3
SHIFT SHAFT	D4

CHASSIS

FRAME	D5
FENDER	D6
SIDE COVER	D9
REAR ARM	D11
REAR SUSPENSION	D12
STEERING	D13
FRONT FORK	D14
FUEL TANK	E2
SEAT	E5
FRONT WHEEL	E6
FRONT BRAKE CALIPER	E7
REAR WHEEL	E8

REAR BRAKE CALIPER	E10
STEERING HANDLE. CABLE	E11
FRONT MASTER CYLINDER	E12
STAND. FOOTREST	E14
REAR MASTER CYLINDER	F2
COWLING 1	F4
GENERATOR	F7
FLASHER LIGHT	F8
METER	F9
HEADLIGHT	F11
TAILLIGHT	F12
HANDLE SWITCH. LEVER	F13
ELECTRICAL 1	F14
ELECTRICAL 2	F15

INDEX

NUMERICAL INDEX	M1
-----------------------	----

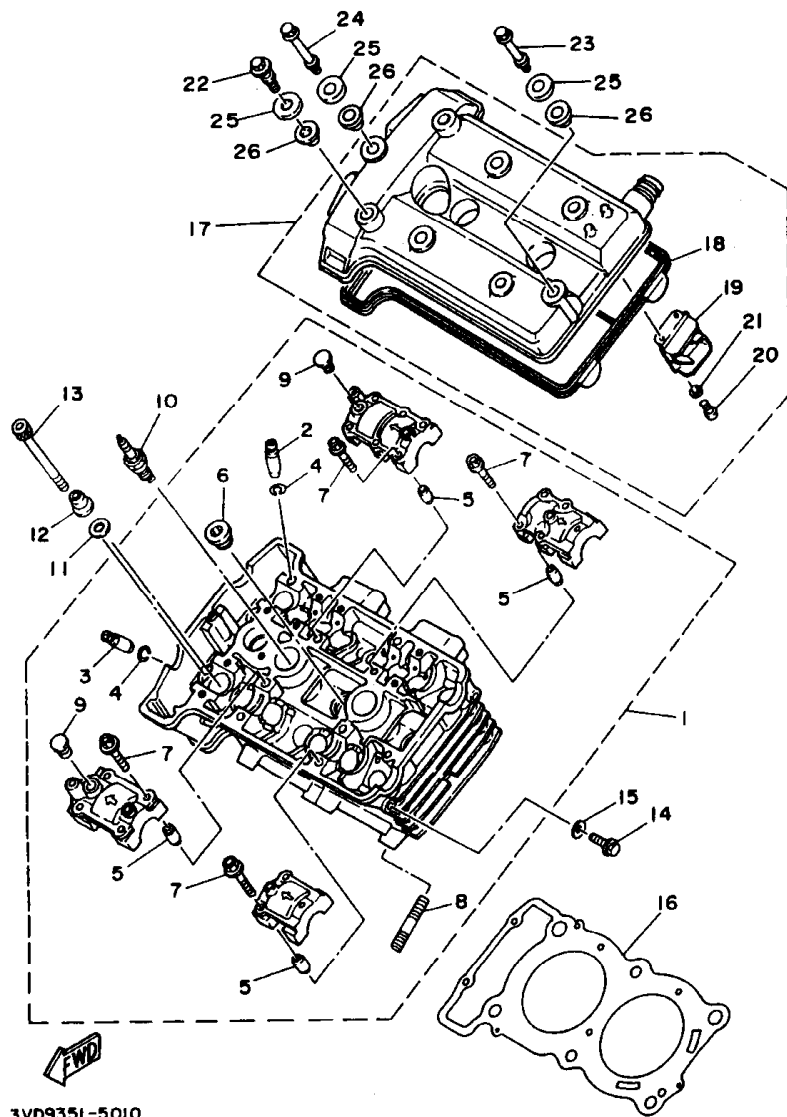

3VD9351-5010

FIG. 1 CYLINDER HEAD

REF. NO.	PART NO.	DESCRIPTION	4TX3	5AR2	REMARKS
1	3VD-11101-20	CYLINDER HEAD ASSY	1	1	
2	3LD-11133-10	.GUIDE, INTAKE VALVE	6	6	
3	3LD-11134-10	.GUIDE, EXHAUST VALVE	4	4	
4	93440-10109	.CIRCLIP	10	10	
5	99510-08016	.PIN, DOWEL	8	8	
6	90340-18101	.PLUG, STRAIGHT SCREW	2	2	
7	90105-06153	.BOLT, WASHER BASED	16	16	
8	90116-08548	.BOLT, STUD	4	4	
9	90338-10150	.PLUG	2	2	
10	94701-00241	PLUG, SPARK (NGK DPR8EA-9)	2	2	UR
	94701-00242	PLUG, SPARK (ND X24EPR-U9)	2	2	UR
11	90201-103M4	WASHER, PLATE	6	6	
12	90179-10414	NUT	6	6	
13	91317-06150	BOLT	2	2	
14	95024-08012	BOLT, FLANGE	1	1	
15	90430-08119	GASKET	1	1	
16	4NX-11181-00	GASKET, CYLINDER HEAD 1	1	1	
17	4NX-Y1119-10	COVER ASSY, CYLINDER HEAD	1	1	
18	3LD-11193-01	.GASKET, HEAD COVER 1	1	1	
19	3LD-11180-02	.BREATHER ASSY	1	1	
20	98507-04006	.SCREW, PAN HEAD	2	2	
21	92907-04600	.WASHER	2	2	
22	90109-064F0	BOLT	6	6	
23	90109-062G1	BOLT	1	1	
24	90109-062G2	BOLT	1	1	
25	90209-11262	WASHER	8	8	
26	2GH-1111G-00	RUBBER, MOUNT 1	8	8	

FIG. 3 CRANKSHAFT. PISTON

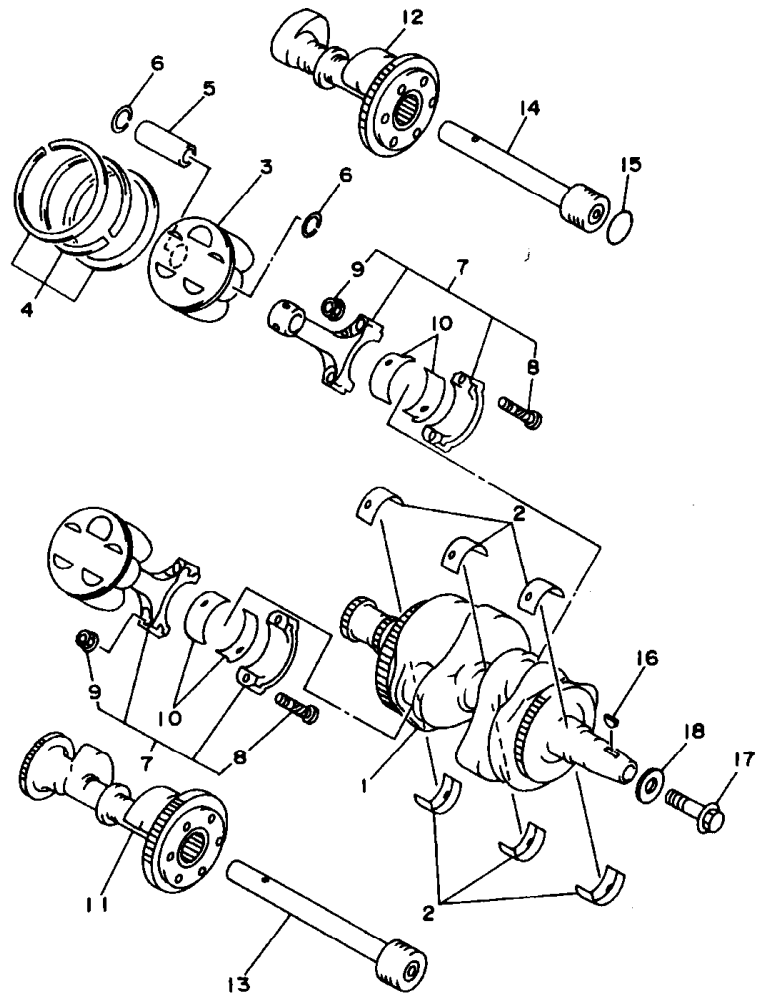

REF. NO.	PART NO.	DESCRIPTION	4TX3	5AR2	REMARKS
1	4NX-11400-00	CRANKSHAFT ASSY	1	1	
2	3LD-11416-00	PLANE BEARING, CRANKSHAFT 1	6	6	UR BLUE
	3LD-11416-10	PLANE BEARING, CRANKSHAFT 1	6	6	UR BLACK
	3LD-11416-20	PLANE BEARING, CRANKSHAFT 1	6	6	UR BROWN
	3LD-11416-30	PLANE BEARING, CRANKSHAFT 1	6	6	UR GREEN
	3LD-11416-40	PLANE BEARING, CRANKSHAFT 1	6	6	UR YELLOW
	3LD-11416-50	PLANE BEARING, CRANKSHAFT 1	6	6	UR PINK
	3LD-11416-60	PLANE BEARING, CRANKSHAFT 1	6	6	UR RED
3	4NX-11631-00	PISTON (STD)	2	2	
	4NX-11636-00	PISTON (0.50MM O/S)	2	2	AP
	4NX-11638-00	PISTON (1.00MM O/S)	2	2	AP
4	3VD-11610-00	PISTON RING SET (STD)	2	2	
	3VD-11610-20	PISTON RING SET (0.50MM O/S)	2	2	AP
	3VD-11610-40	PISTON RING SET (1.00MM O/S)	2	2	AP
5	3LD-11633-00	PIN, PISTON	2	2	
6	93450-22027	CIRCLIP	4	4	
7	3VD-11650-00	CONNECTING ROD ASSY	2	2	
8	3LD-11654-00	.BOLT, CONNECTING ROD	2	2	
9	90179-09379	.NUT	2	2	
10	3LD-11656-00	PLANE BEARING, CONNECTING ROD	4	4	UR BLUE
	3LD-11656-10	PLANE BEARING, CONNECTING ROD	4	4	UR BLACK
	3LD-11656-20	PLANE BEARING, CONNECTING ROD	4	4	UR BROWN
	3LD-11656-30	PLANE BEARING, CONNECTING ROD	4	4	UR GREEN
11	4NX-11500-00	BALANCER ASSY	1	1	
12	4NX-11510-00	BALANCER ASSY, 2	1	1	
13	3LD-11583-00	SHAFT, BALANCER 1	1	1	
14	3LD-11584-00	SHAFT, BALANCER 2	1	1	

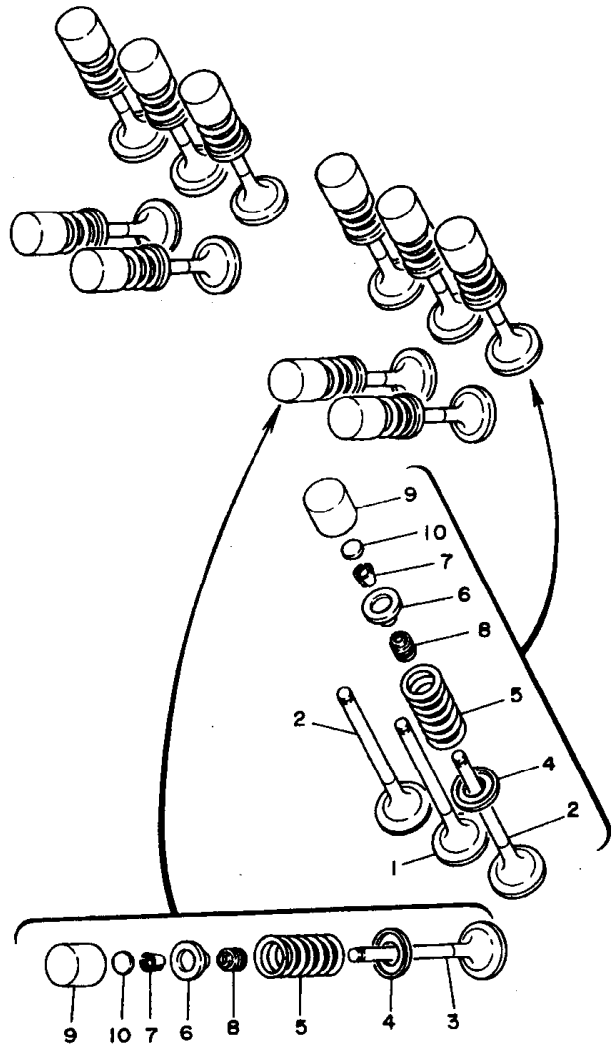

3LD135I-9040

FIG. 4 VALVE

REF. NO.	PART NO.	DESCRIPTION	4TX3	5AR2	REMARKS
1	3LD-12111-01	VALVE, INTAKE (3LD.)	2	2	
2	3LD-12112-01	VALVE, INTAKE 2 (3LD.)	4	4	
3	3LD-12121-00	VALVE, EXHAUST (3LD)	4	4	
4	1WG-12116-00	SEAT, VALVE SPRING	10	10	
5	3LD-12113-00	SPRING, VALVE INNER	10	10	BLUE
6	3LD-12117-00	RETAINER, VALVE SPRING	10	10	
7	3LD-12118-00	COTTER, VALVE	20	20	
8	51Y-12119-00	SEAL, VALVE STEM	10	10	
9	1WG-12153-11	LIFTER, VALVE	10	10	UR YELLOW
	1WG-12153-21	LIFTER, VALVE	10	10	UR BLUE
	1WG-12153-31	LIFTER, VALVE	10	10	UR RED
	1WG-12153-09	LIFTER, VALVE (O/S)	10	10	AP WHITE
10	3LD-12168-00	PAD, ADJUSTING (1.20)	10	10	UR
	3LD-12168-20	PAD, ADJUSTING (1.25)	10	10	UR
	3LD-12168-40	PAD, ADJUSTING (1.30)	10	10	UR
	3LD-12168-60	PAD, ADJUSTING (1.35)	10	10	UR
	3LD-12168-80	PAD, ADJUSTING (1.40)	10	10	UR
	3LD-12168-A0	PAD, ADJUSTING (1.45)	10	10	UR
	3LD-12168-F0	PAD, ADJUSTING (1.50)	10	10	UR
	3LD-12168-H1	PAD, ADJUSTING (1.55)	10	10	UR
	3LD-12168-K1	PAD, ADJUSTING (1.60)	10	10	UR
	3LD-12168-M1	PAD, ADJUSTING (1.65)	10	10	UR
	3LD-12168-R1	PAD, ADJUSTING (1.70)	10	10	UR
	3LD-12168-U1	PAD, ADJUSTING (1.75)	10	10	UR
	3LD-12168-W1	PAD, ADJUSTING (1.80)	10	10	UR
	3LD-12168-Y1	PAD, ADJUSTING (1.85)	10	10	UR
	3LD-12169-11	PAD, ADJUSTING (1.90)	10	10	UR

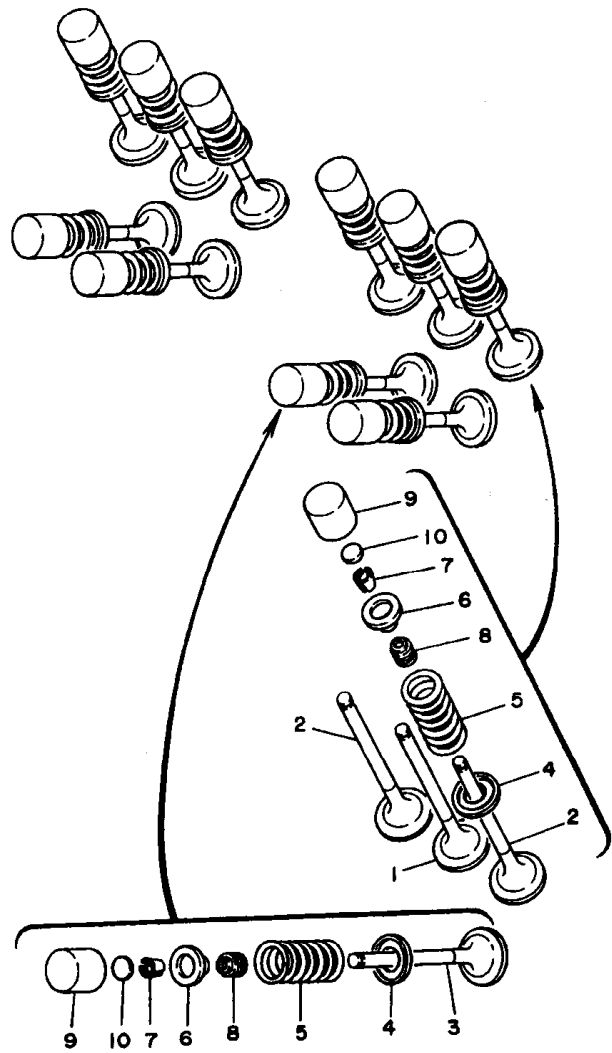

3LD1351-9040

FIG. 4 VALVE

REF. NO.	PART NO.	DESCRIPTION	4TX3	5AR2	REMARKS
10	3LD-12169-31	PAD, ADJUSTING (1.95)	10	10	UR
	3LD-12169-50	PAD, ADJUSTING (2.00)	10	10	UR
	3LD-12169-70	PAD, ADJUSTING (2.05)	10	10	UR
	3LD-12169-90	PAD, ADJUSTING (2.10)	10	10	UR
	3LD-12169-E0	PAD, ADJUSTING (2.15)	10	10	UR
	3LD-12169-G0	PAD, ADJUSTING (2.20)	10	10	UR
	3LD-12169-J0	PAD, ADJUSTING (2.25)	10	10	UR
	3LD-12169-L0	PAD, ADJUSTING (2.30)	10	10	UR
	3LD-12169-N0	PAD, ADJUSTING (2.35)	10	10	UR
	3LD-12169-T0	PAD, ADJUSTING (2.40)	10	10	UR

B7

FIG. 5 CAMSHAFT. CHAIN

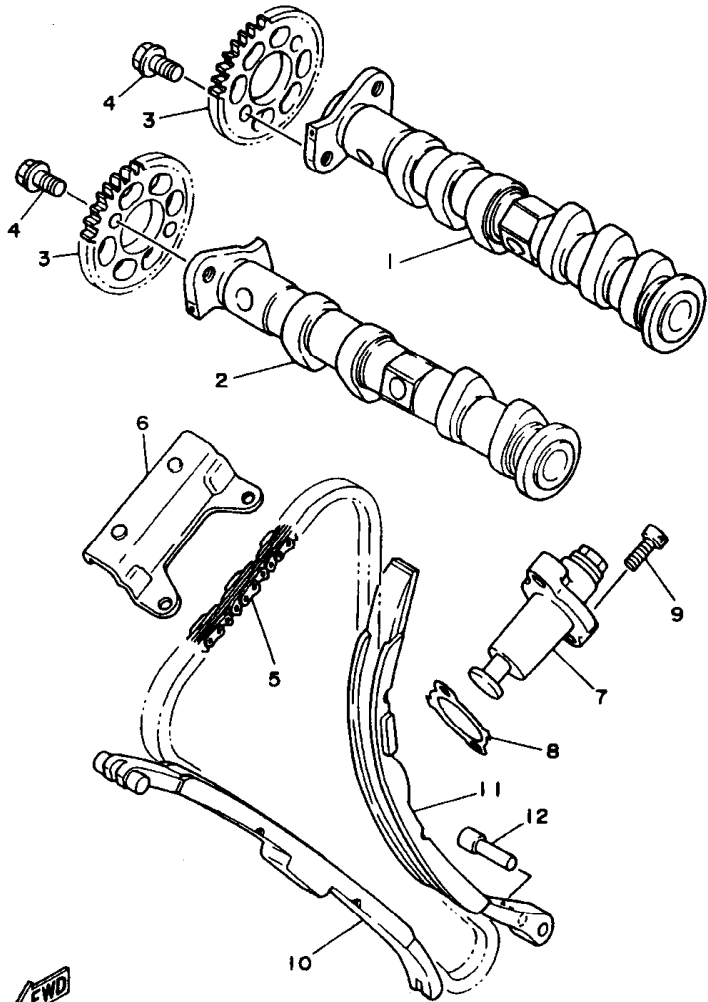

3VD9351-5050

REF. NO.	PART NO.	DESCRIPTION	4TX3	5AR2	REMARKS
1	4NX-12171-00	CAMSHAFT 1	1	1	
2	4NX-12181-00	CAMSHAFT 2	1	1	
3	3LD-12176-00	SPROCKET, CAM CHAIN	2	2	
4	90105-07342	BOLT, WASHER BASED	4	4	
5	94591-40138	CHAIN (82RH2015-138L)	1	1	
6	3LD-12241-00	GUIDE, STOPPER 2	1	1	
7	3LD-12210-00	TENSIONER ASSY, CAM CHAIN	1	1	
8	3VD-12213-00	GASKET, TENSIONER CASE	1	1	
9	91314-06025	BOLT	2	2	
10	3LD-12251-00	DAMPER, CHAIN 1	1	1	
11	3LD-12252-00	DAMPER, CHAIN 2	1	1	
12	3LD-12247-00	SHAFT, TENSIONER	1	1	

FIG. 6 WATER PUMP

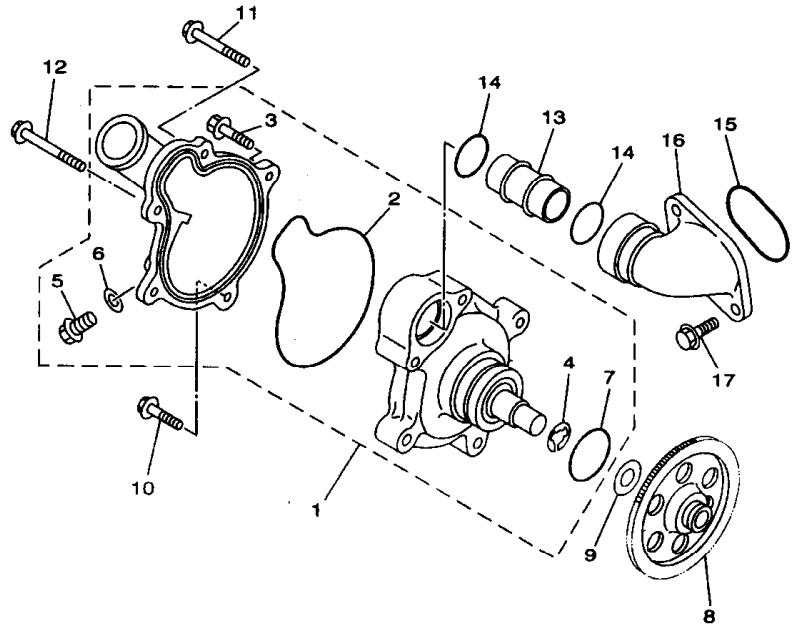

REF. NO.	PART NO.	DESCRIPTION	4TX3	5AP2	REMARKS
1	4UN-Y1242-00	WATER PUMP ASSY	1	1	
2	3LD-12439-00	.O-RING	1	1	
3	95024-06020	.BOLT, FLANGE	2	2	
4	99009-12400	.CIRCLIP	1	1	
5	95024-06012	.BOLT, FLANGE	1	1	
6	90430-06014	.GASKET	1	1	
7	93210-33133	.O-RING	1	1	
8	3VD-12459-00	GEAR, IMPELLER SHAFT	1	1	
9	90201-127E1	WASHER, PLATE	1	1	
10	95024-06030	BOLT, FLANGE	1	1	
11	95024-06045	BOLT, FLANGE	1	1	
12	95024-06060	BOLT, FLANGE	1	1	
13	3LD-12481-00	PIPE 1	1	1	
14	93210-21190	O-RING	2	2	
15	93210-36788	O-RING	1	1	
16	4UN-12469-00	JOINT 1	1	1	
17	95027-06016	BOLT, FLANGE	2	2	

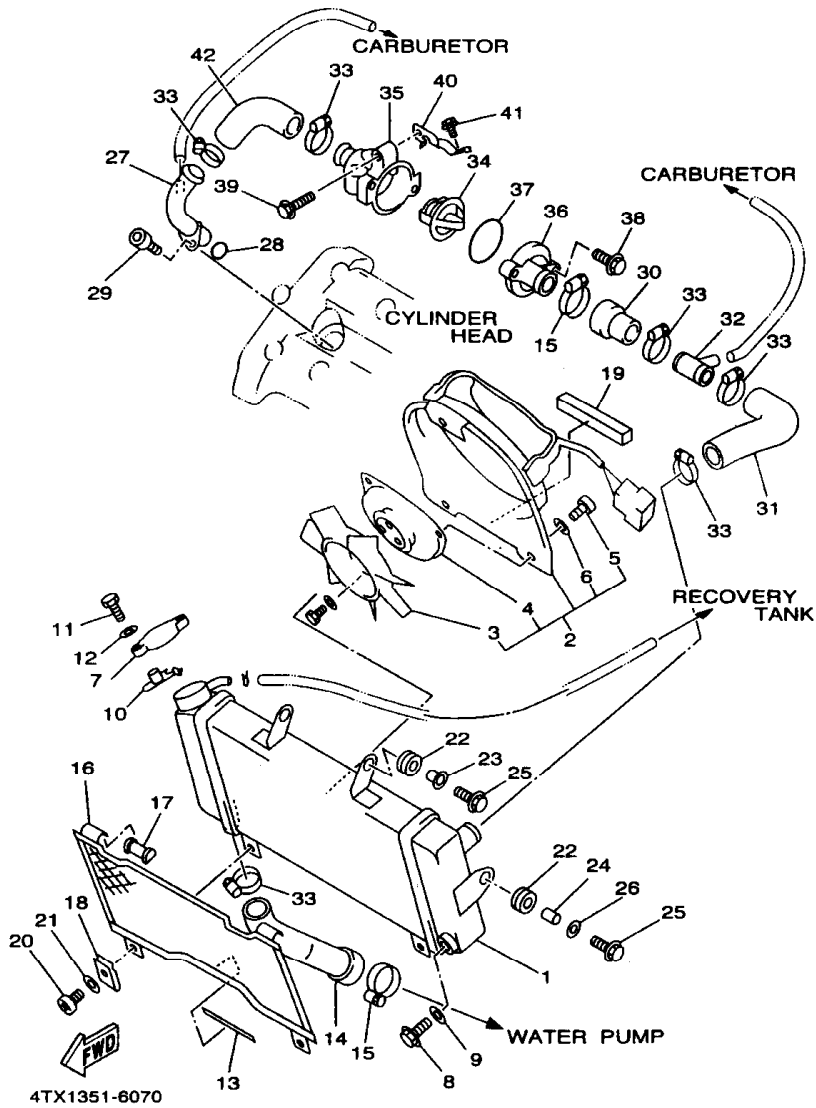

4TX1351-6060

FIG. 7 RADIATOR. HOSE

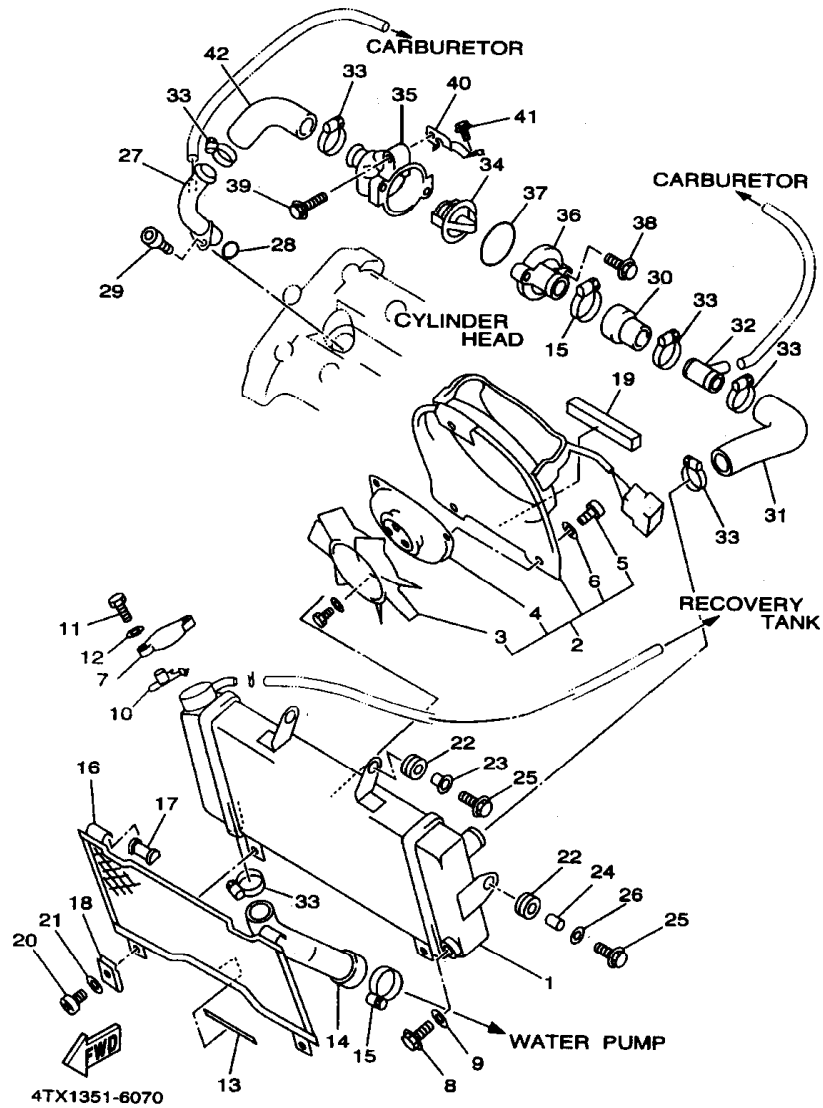

REF. NO.	PART NO.	DESCRIPTION	4TX3	5AP2	REMARKS
1	4TX-12461-00	RADIATOR ASSY	1	1	
2	4TX-12405-00	BLOWER ASSY	1	1	
3	1UF-12611-00	.FAN	1	1	
4	26H-12630-00	.MOTOR ASSY	1	1	
5	98507-05008	.SCREW, PAN HEAD	3	3	
6	92990-05600	.WASHER, PLATE	3	3	
7	4FL-12482-00	CAP, RADIATOR	1	1	
8	1AA-12561-00	PLUG,DRAIN COCK	1	1	
9	1AA-12435-00	GASKET	1	1	
10	1KT-12437-00	STOPPER	1	1	
11	97007-05012	BOLT	1	1	
12	92907-05600	WASHER, PLATE	1	1	
13	3VD-12465-00	DAMPER, RADIATOR	1	1	
14	4TX-12578-00	HOSE 3	1	1	
15	90450-38040	HOSE CLAMP ASSY	2	2	
16	1UF-12467-00	COVER, RADIATOR	1	1	
17	1UF-12435-00	GASKET	2	2	
18	90183-05024	NUT, SPRING	2	2	
19	4TX-12465-00	DAMPER, RADIATOR	1	1	
20	98507-05010	SCREW, PAN HEAD	2	2	
21	92907-05600	WASHER, PLATE	2	2	
22	90480-15363	GROMMET	4	4	
23	90387-0700G	COLLAR	2	2	
24	90387-07390	COLLAR	2	2	
25	95807-06025	BOLT, FLANGE	4	4	
26	90201-06071	WASHER, PLATE	2	2	
27	4NX-12482-00	PIPE 2	1	1	

FIG. 7 RADIATOR. HOSE



REF. NO.	PART NO.	DESCRIPTION	4TX3	5AR2	REMARKS
28	93210-18417	O-RING	1	1	
29	91317-06016	BOLT	1	1	
30	4NX-12576-00	HOSE 1	1	1	
31	4NX-12577-00	HOSE 2	1	1	
32	4NX-12481-00	PIPE 1	1	1	
33	90450-32051	HOSE CLAMP ASSY	6		
	90450-32015	HOSE CLAMP ASSY		6	
34	1AE-12410-00	THERMOSTAT ASSY	1	1	
35	4NX-12417-00	HOUSING, THERMOSTAT	1	1	
36	4NX-12413-00	COVER, THERMOSTAT	1	1	
37	93210-49046	O-RING	1	1	
38	95027-06020	BOLT, FLANGE	2	2	
39	95027-06025	BOLT, FLANGE	1	1	
40	4TX-1244E-00	BRACKET 1	1	1	
41	95027-06014	BOLT, FLANGE	1	1	
42	4NX-12579-00	HOSE 4	1	1	

FIG. 8 OIL PUMP

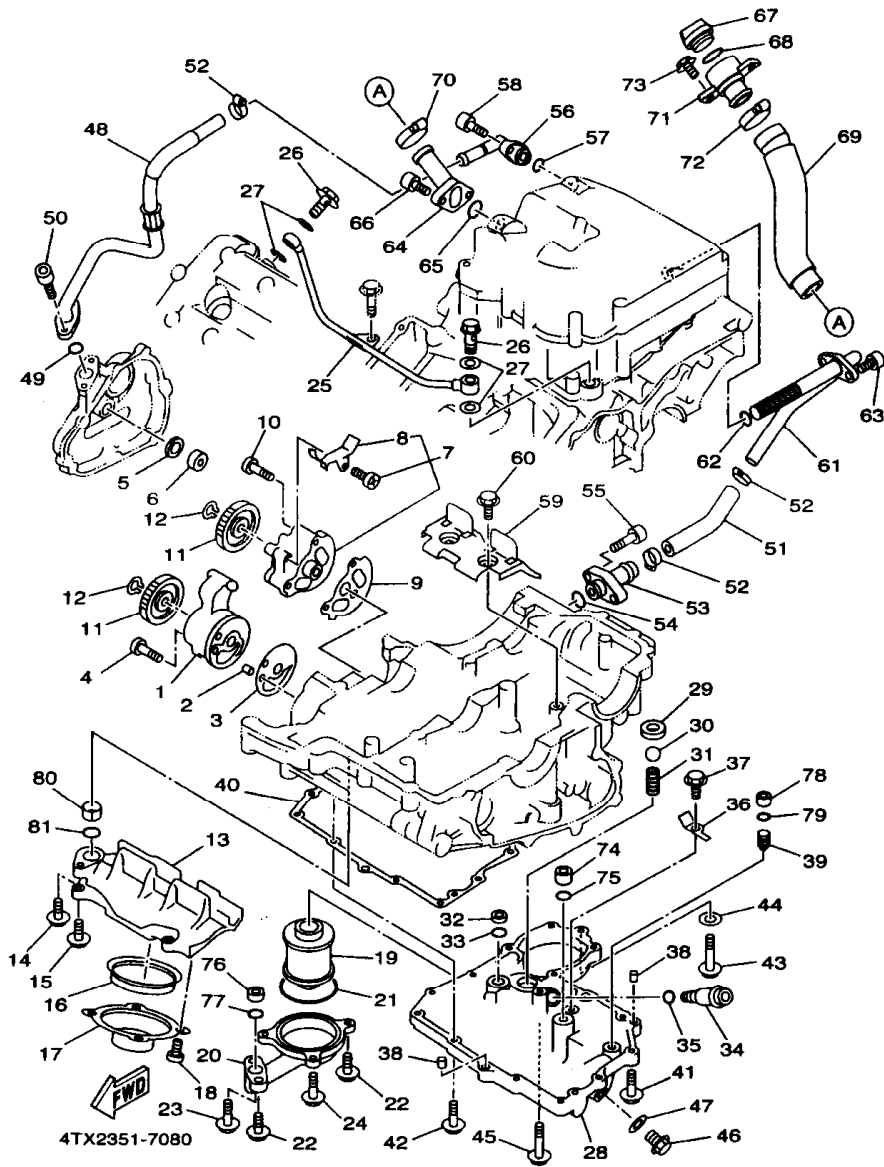

REF. NO.	PART NO.	DESCRIPTION	4TX3	5AR2	REMARKS
1	3LD-13300-00	OIL PUMP ASSY	1	1	
2	99530-08012	PIN, DOWEL	1	1	
3	3LD-13329-00	GASKET, PUMP COVER	1	1	
4	98507-06045	SCREW, PAN HEAD	3	3	
5	90430-14131	GASKET	1	1	
6	90387-120W5	COLLAR	1	1	
7	4NX-13303-00	OIL PUMP ASSY, 2	1	1	
8	3LD-13371-00	.PLATE	1	1	
9	3LD-13339-00	GASKET, PUMP COVER	1	1	
10	98507-06035	SCREW, PAN HEAD	3	3	
11	3VD-13325-00	GEAR, PUMP DRIVEN	2	2	
12	99009-11400	CIRCLIP	2	2	
13	3VD-13412-00	HOUSING, STRAINER	1	1	
14	95027-06025	BOLT, FLANGE	1	1	
15	95027-06020	BOLT, FLANGE	4	4	
16	3VD-13415-00	SEAL, OIL STRAINER	1	1	
17	3VD-13411-00	STRAINER, OIL	1	1	
18	98507-06010	SCREW, PAN HEAD	4	4	
19	4X7-13440-01	ELEMENT ASSY, OIL CLEANER	1	1	
20	3VD-13447-00	COVER, OIL ELEMENT	1	1	
21	93210-64297	O-RING	1	1	
22	95024-06020	BOLT, FLANGE	2	2	
23	95024-06030	BOLT, FLANGE	1	1	
24	95024-06040	BOLT, FLANGE	2	2	
	95027-06040	BOLT, FLANGE		2	

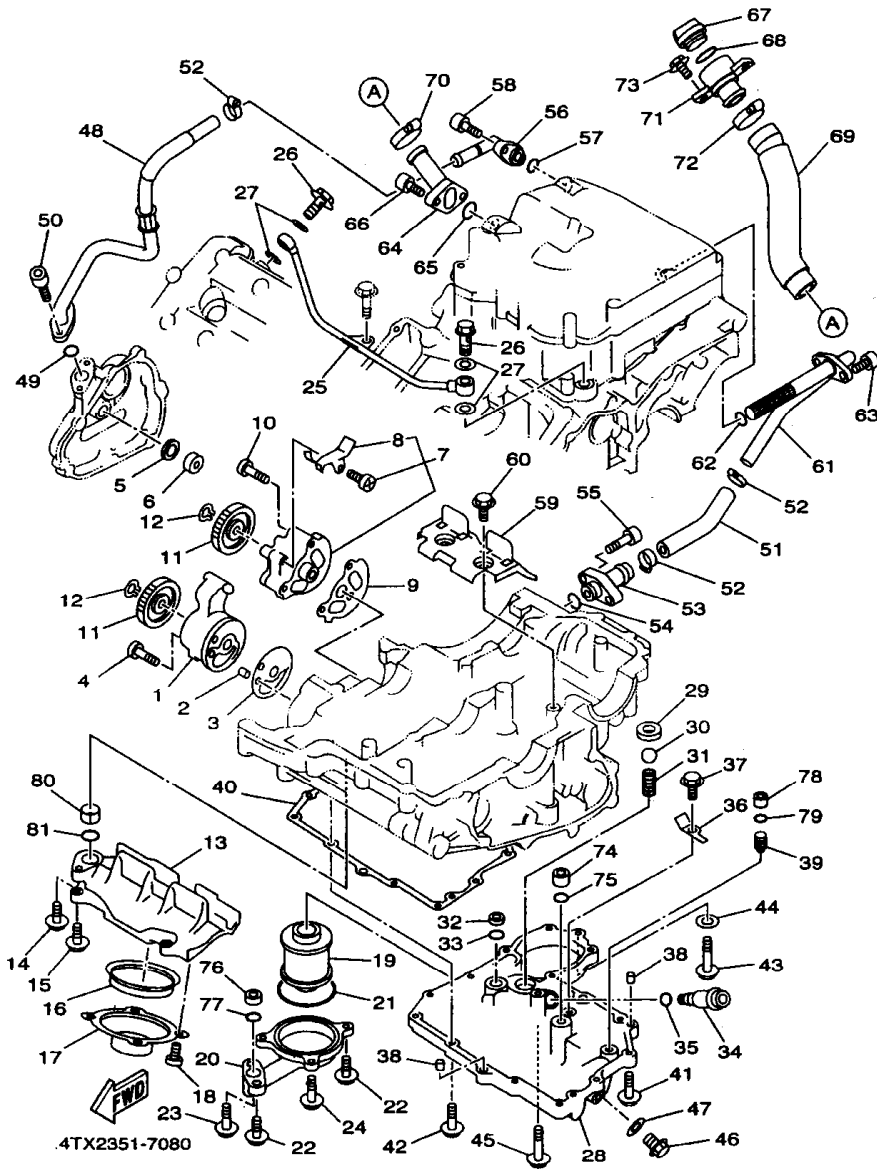

FIG. 8 OIL PUMP

REF. NO.	PART NO.	DESCRIPTION	4TX3	5AR2	REMARKS
25	3LD-13161-00	PIPE, DELIVERY 1	1	1	
26	90401-10106	BOLT, UNION	2	2	
27	90430-10188	GASKET	4	4	
28	3VD-13417-10	COVER, STRAINER	1	1	
29	3LD-13113-00	SEAT, CHECK BALL	1	1	
30	93505-08030	BALL	1	1	
31	90501-104F9	SPRING, COMPRESSION	1	1	
32	90387-106W6	COLLAR	1	1	
33	93210-12790	O-RING	1	1	
34	11H-13490-00	RELIEF VALVE ASSY	1	1	
35	93210-10096	O-RING	1	1	
36	3LD-13151-00	STAY	1	1	
37	90105-06553	BOLT, WASHER BASED	1	1	
38	99530-08016	PIN, DOWEL	2	2	
39	4H7-15138-00	NOZZLE 1	1	1	
40	3VD-13414-00	GASKET, STRAINER COVER	1	1	
41	90105-06456	BOLT, WASHER BASED	2	2	
42	95024-06025	BOLT, FLANGE	11		
	95027-06025	BOLT, FLANGE		11	
43	95024-10040	BOLT, FLANGE	1		
	95027-10040	BOLT, FLANGE		1	
44	90430-10188	GASKET	1	1	
45	95027-06035	BOLT, FLANGE	1	1	
46	90340-14132	PLUG, STRAIGHT SCREW	1	1	
47	214-11198-01	GASKET	1	1	
48	4UN-13464-01	HOSE, OIL 1	1	1	
49	93210-13657	O-RING	1	1	

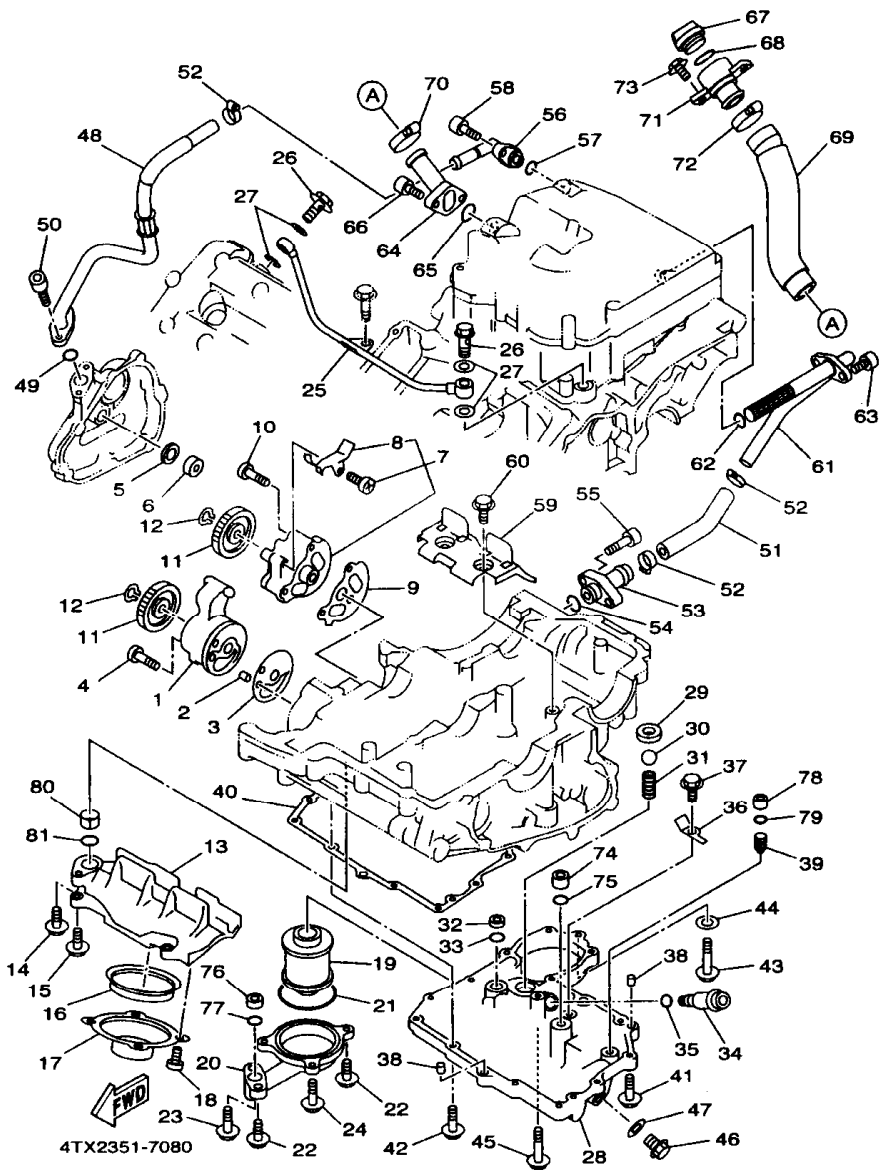
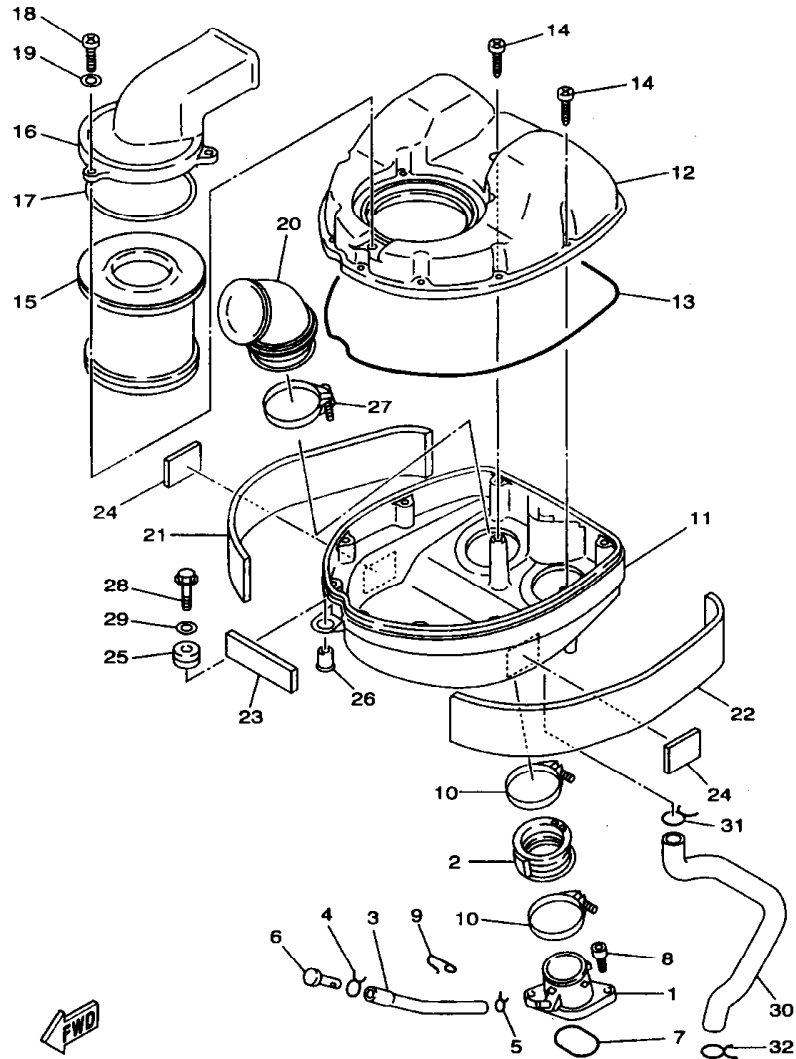

FIG. 8 OIL PUMP

REF. NO.	PART NO.	DESCRIPTION	4TX3	5AR2	REMARKS
50	91314-06020	BOLT	2	2	
51	4TX-13465-00	HOSE, OIL 2	1	1	
52	90460-27270	CLAMP, HOSE	3	3	
53	3VD-13416-00	PIPE, OIL 1	1	1	
54	93210-13657	O-RING	1	1	
55	90110-06093	BOLT, HEXAGON SOCKET HEAD	2	2	
56	4NX-13418-00	PIPE, OIL 2	1	1	
57	93210-13657	O-RING	1	1	
58	91314-06020	BOLT	2		
	91317-06020	BOLT		2	
59	3VD-13317-00	PLATE, BAFFLE	1	1	
60	90105-06553	BOLT, WASHER BASED	2	2	
61	4TX-13416-00	PIPE, OIL 1	1	1	
62	93210-16629	O-RING	1	1	
63	91314-06020	BOLT	2		
	91317-06020	BOLT		2	
64	4TX-13132-00	JOINT	1	1	
65	93210-26741	O-RING	1	1	
66	91314-06025	BOLT	2		
	91317-06025	BOLT		2	
67	3F9-15362-00	PLUG, OIL LEVEL	1	1	
68	93210-27370	O-RING	1	1	
69	4TX-13467-00	HOSE	1	1	
70	90450-32051	HOSE CLAMP ASSY	1		
	90450-32015	HOSE CLAMP ASSY		1	
71	4TX-13266-00	CONNECTOR, OIL	1	1	
72	90450-38040	HOSE CLAMP ASSY	1	1	

FIG. 9 INTAKE



4TX1351-6090

REF. NO.	PART NO.	DESCRIPTION			REMARKS
			4TX3	5AR2	
1	3LD-13586-01	JOINT, CARBURETOR 1	2	2	
2	3LD-13597-01	JOINT, CARBURETOR 3	2	2	
3	90445-090E5	HOSE	1	1	
4	90467-08017	CLIP	1	1	
5	90467-08075	CLIP	1	1	
6	90338-05194	PLUG	1	1	
7	93210-44545	O-RING	2	2	
8	91317-06020	BOLT	4	4	
9	90465-20035	CLAMP	1	1	
10	90450-57034	HOSE CLAMP ASSY	4	4	
11	3VD-14411-00	CASE, AIR CLEANER 1	1	1	
12	3VD-14421-00	CASE, AIR CLEANER 2	1	1	
13	4BR-14452-00	SEAL	1	1	
14	97707-50125	SCREW, TAPPING	10	10	
15	1AE-14451-00	ELEMENT, AIR CLEANER	1	1	
16	3VD-14422-00	CAP, CLEANER CASE 2	1	1	
17	1AE-14452-00	SEAL	1	1	
18	98507-05016	SCREW, PAN HEAD	3	3	
19	92907-05600	WASHER, PLATE	3	3	
20	4TX-14453-00	JOINT, AIR CLEANER 1	2	2	
21	3VD-14425-00	DAMPER 1	1	1	
22	3VD-14426-00	DAMPER 2	1	1	
23	3VD-1442G-00	DAMPER 3	1	1	
24	4N0-24181-00	DAMPER, LOCATING 1	2	2	
25	90480-14604	GROMMET	1	1	
26	90387-07391	COLLAR	1	1	
27	90450-67068	HOSE CLAMP ASSY	2	2	

FIG. 9 INTAKE

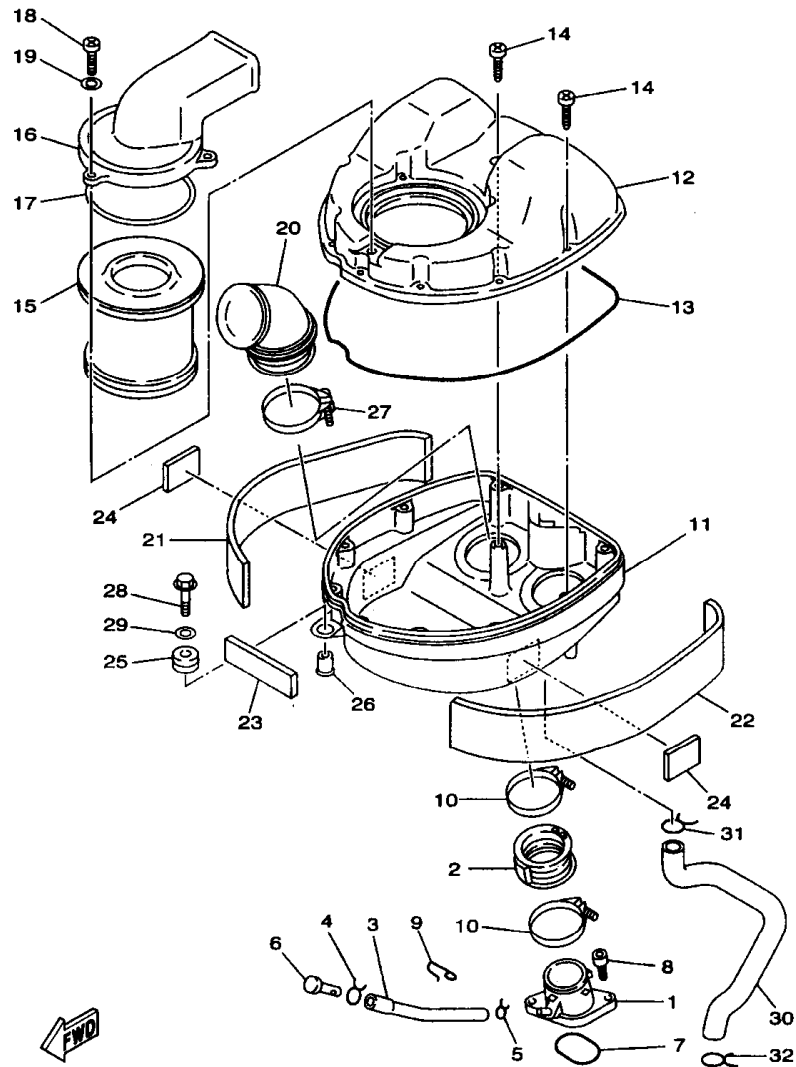

4TX1351-6090

REF. NO.	PART NO.	DESCRIPTION			REMARKS
			4TX3	5AR2	
28	97007-06025	BOLT	1	1	
29	90201-06063	WASHER, PLATE	1	1	
30	4TX-11166-01	PIPE, BREATHER 1	1	1	
31	90467-22080	CLIP	1	1	
32	90467-24113	CLIP	1	1	

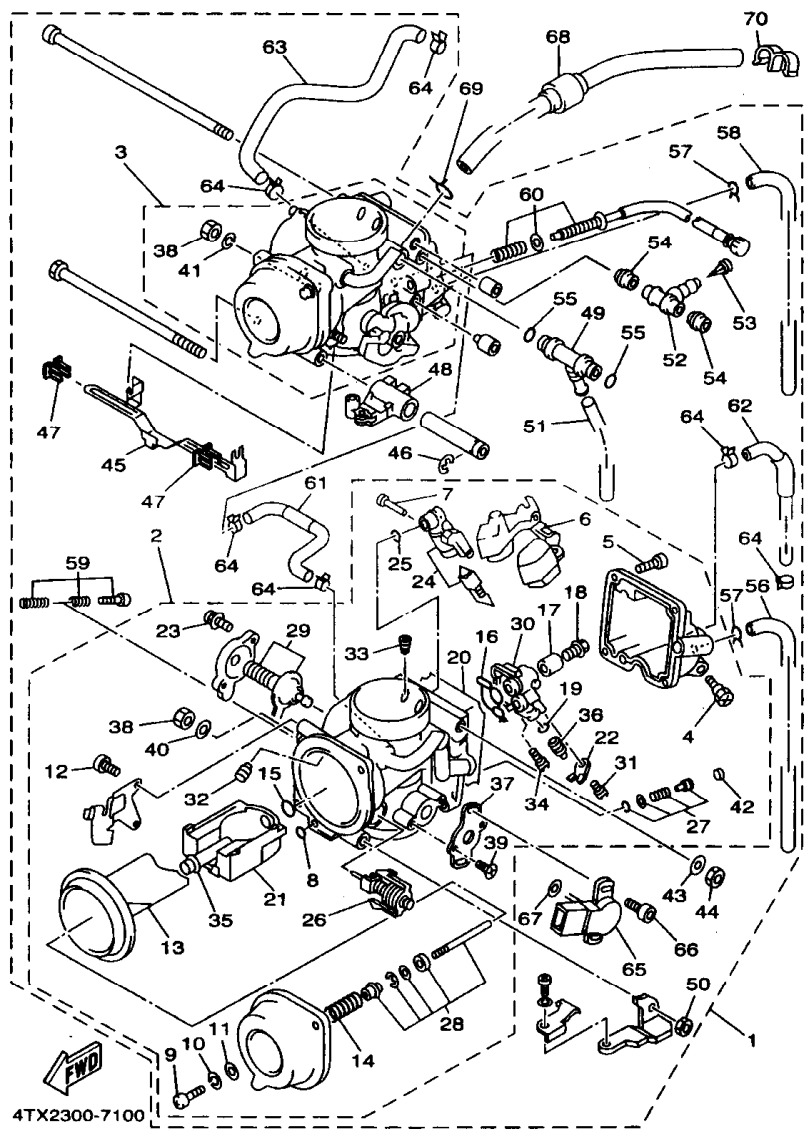
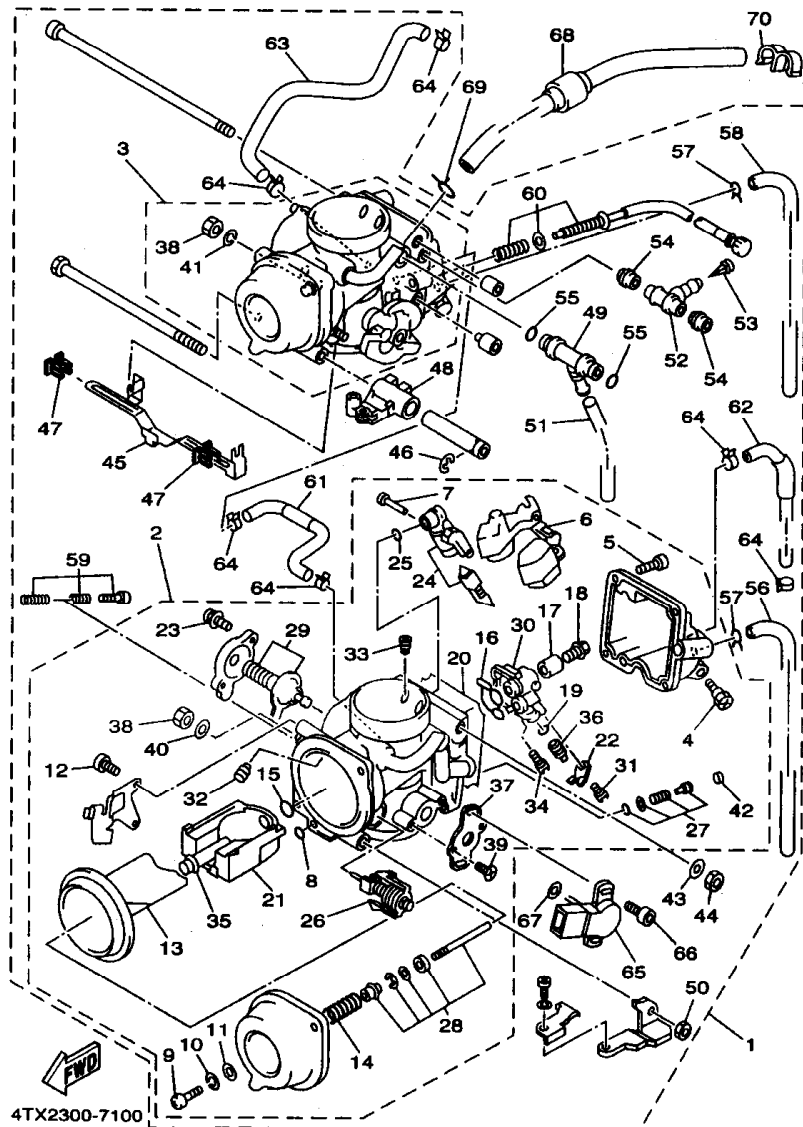

FIG. 10 CARBURETOR

REF. NO.	PART NO.	DESCRIPTION			REMARKS
			4TX3	5AR2	
1	4TX-14900-00	CARBURETOR ASSY	1		
	5AR-14900-00	CARBURETOR ASSY		1	
2	4TX-14901-00	.CARBURETOR ASSY 1	1		
	5AR-14901-00	.CARBURETOR ASSY 1		1	
3	4TX-14902-00	.CARBURETOR ASSY 2	1		
	5AR-14902-00	.CARBURETOR ASSY 2		1	
4	3FV-14191-00	..PLUG, DRAIN	1	1	
5	98501-05012	..SCREW, PAN HEAD	4	4	
6	3GM-14985-00	..FLOAT	1	1	
7	53L-14186-00	..PIN, FLOAT	1	1	
8	3FV-14147-00	..O-RING	1	1	
9	98507-05016	..SCREW, PAN HEAD	2	2	
10	92907-05100	..WASHER, SPRING	2	2	
11	92907-05600	..WASHER, PLATE	2	2	
12	98507-04008	..SCREW, PAN HEAD	2	2	
13	3GM-14940-00	..DIAPHRAGM ASSY	1	1	
14	4TX-14933-00	..SPRING, DIAPHRAGM	1	1	
15	1AE-14147-00	..O-RING	1	1	
16	3LF-14147-00	..O-RING	1	1	
17	3GM-14153-00	..WASHER, MAIN JET	1	1	
18	1HX-14565-00	..SCREW	1	1	
19	3LD-14147-00	..O-RING	1	1	
20	3GM-14997-00	..SEAL	1	1	
21	3GM-1411E-00	..BLOCK, JET	1	1	
22	3LD-14945-00	..JET	1	1	
23	1UY-14565-00	..SCREW	2	2	
24	3GM-14107-17	..NEEDLE VALVE SET	1	1	

FIG. 10 CARBURETOR



REF. NO.	PART NO.	DESCRIPTION	4TX3	5AR2	REMARKS
25	3EN-14147-00	..O-RING	1	1	
26	3EN-1410A-00	..STARTER SET	1	1	
27	12R-14105-00	..PILOT SCREW SET	1		
	4CC-14105-00	..PILOT SCREW SET		1	
28	4NX-1490J-00	..NEEDLE SET	1	1	
29	3LD-1490H-00	..DIAPHRAGM SET 5	1		
	5AR-1490H-00	..DIAPHRAGM SET 5		1	
30	4TX-1411A-00	..BLOCK JET ASSY	1	1	
31	620-14231-15	..JET, MAIN (# 75)	1	1	
32	239-14172-14	..PILOT JET, AIR (1.4)	1	1	
33	830-14231-14	..JET, MAIN (# 70)	1	1	
34	4G0-14142-45	..JET, PILOT (# 45)	1		
	4G0-14142-42	..JET, PILOT (# 42.5)		1	
35	3GM-14141-92	..NOZZLE, MAIN	1		
	3GM-14141-93	..NOZZLE, MAIN		1	
36	3LD-1423A-79	..JET, MAIN (#142.5)	1	1	
37	4TX-14995-00	..BRACKET	1	1	
38	812-14594-00	..NUT	1	1	
39	98707-04008	..SCREW, FLAT HEAD	2	2	
40	4G0-14953-00	..WASHER	1	1	
41	92907-08100	..WASHER, SPRING	1	1	
42	2RJ-14118-00	..CAP		1	
43	92907-05600	..WASHER, PLATE	1	1	
44	95307-05600	..NUT	1	1	
45	3LD-14986-00	..LEVER, STARTER	1	1	
46	3LD-14919-00	..CLIP	1	1	
47	3EN-14261-00	..HOLDER	2	2	

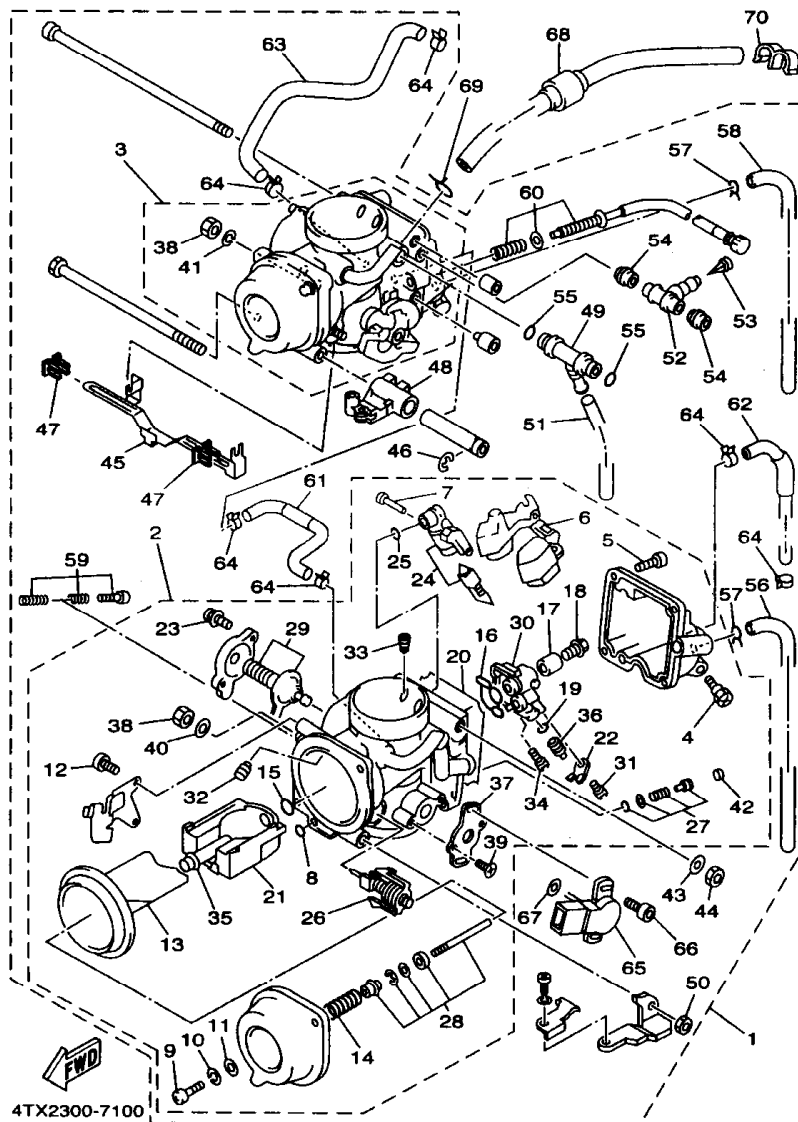
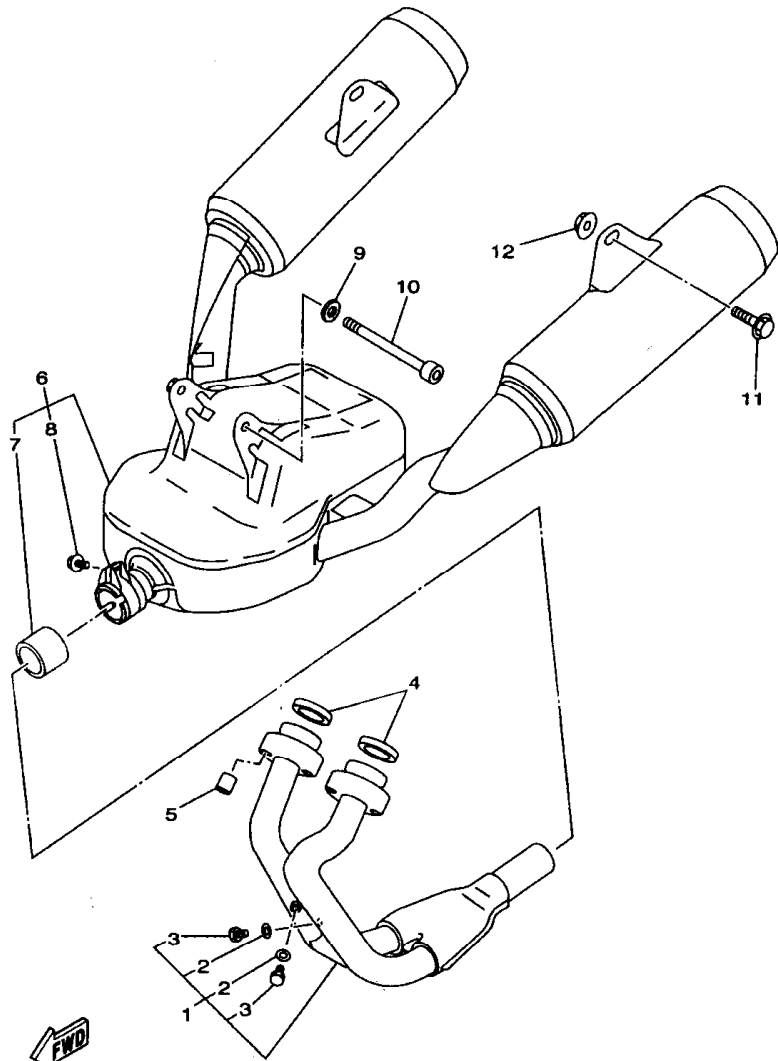

FIG. 10 CARBURETOR

REF. NO.	PART NO.	DESCRIPTION	4TX3	5AR2	REMARKS
48	3GM-14974-00	.LEVER, CONNECT	1	1	
49	3LD-14988-00	.PIPE, STARTER CONNECTING	1	1	
50	95307-06600	.NUT	1	1	
51	2LH-14197-00	.PIPE	1	1	
52	3EN-14988-00	.PIPE, STARTER CONNECTING	1	1	
53	1KT-14994-00	.NET, FILTER	1	1	
54	3EN-14997-00	.SEAL	2	2	
55	822-14147-00	.O-RING	2	2	
56	4TX-14987-00	.HOSE	1	1	
57	90467-07029	.CLIP	2	2	
58	4NX-14987-00	.HOSE	1	1	
59	3EN-1490K-00	.STOP SCREW SET	1	1	
60	4TX-14103-00	.THROTTLE SCREW SET	1	1	
61	4NX-1243E-00	.HOSE 2	1	1	
62	4TX-1243A-00	.HOSE 1	1	1	
63	4NX-1243F-00	.HOSE,3	1	1	
64	90467-07093	.CLIP	6	6	
65	4HM-85885-10	.THROTTLE POSITION SENSOR ASSY	1	1	
66	4HM-14216-00	.SCREW	2	2	
67	4HM-14239-00	.SEAL	1	1	
68	4TX-14148-00	PIPE	2	2	
69	90467-12052	CLIP	2	2	
70	90464-12238	CLAMP	1	1	

FIG. 11 EXHAUST



4TX1351-6110

REF. NO.	PART NO.	DESCRIPTION	4TX3	5AF2	REMARKS
1	4TX-14602-00	EXHAUST PIPE COMP.	1	1	
2	92990-06600	.WASHER, PLATE	2	2	
3	90101-06576	.BOLT	2	2	
4	3VD-14613-00	GASKET, EXHAUST PIPE	2	2	
5	90179-08345	NUT	4	4	
6	4TX-14710-00	MUFFLER ASSY 1	1	1	
7	3VD-14755-00	.GASKET, SILENCER	1	1	
8	95027-08025	.BOLT, FLANGE	1	1	
9	90201-08326	WASHER, PLATE	1	1	
10	91317-08110	BOLT	1	1	
11	90105-10271	BOLT, WASHER BASED	2	2	
12	95707-10500	NUT, FLANGE	2	2	

FIG. 12 CRANKCASE

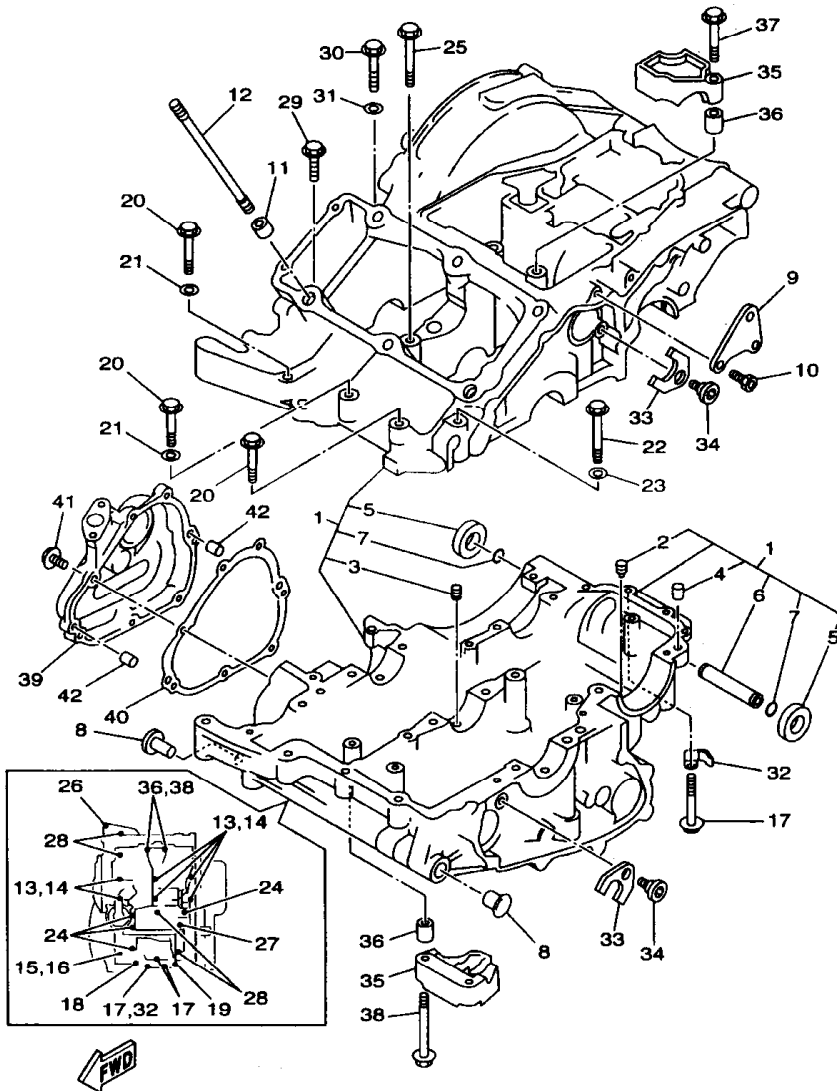

4TX1351-6120

REF. NO.	PART NO.	DESCRIPTION	4TX3	5AP2	REMARKS
1	3VD-15100-21	CRANKCASE ASSY	1	1	
2	2H7-15138-00	.NOZZLE 1	1	1	
3	4G0-15138-00	.NOZZLE 1	1	1	
4	99530-10114	.PIN, DOWEL	1	1	
5	3VD-15316-00	.DAMPER, ENGINE MOUNT 1	2	2	
6	3VD-15317-00	.SPACER, ENGINE MOUNT	1	1	
7	93210-12095	.O-RING	2	2	
8	90338-11257	PLUG	2	2	
9	3VD-15199-00	BRACKET	1	1	
10	91314-08016	BOLT	2		
	91317-08016	BOLT		2	
11	99530-14016	PIN, DOWEL	2	2	
12	3LD-11361-00	BOLT, CYLINDER HOLDING 1	6	6	
13	90105-10560	BOLT, WASHER BASED	6	6	
14	90201-11597	WASHER, PLATE	6	6	
15	95814-06040	BOLT, FLANGE	1		
	95817-06040	BOLT, FLANGE		1	
16	90201-066F0	WASHER, PLATE	1	1	
17	95817-06055	BOLT, FLANGE	3	3	
18	95817-06020	BOLT, FLANGE	1	1	
19	95817-06030	BOLT, FLANGE	1	1	
20	95814-08050	BOLT, FLANGE	3	3	
21	90201-08087	WASHER, PLATE	2	2	
22	95814-08060	BOLT, FLANGE	1	1	
23	90201-08087	WASHER, PLATE	1	1	
24	95817-06070	BOLT, FLANGE	4	4	
25	95817-08065	BOLT, FLANGE	1	1	

FIG. 12 CRANKCASE

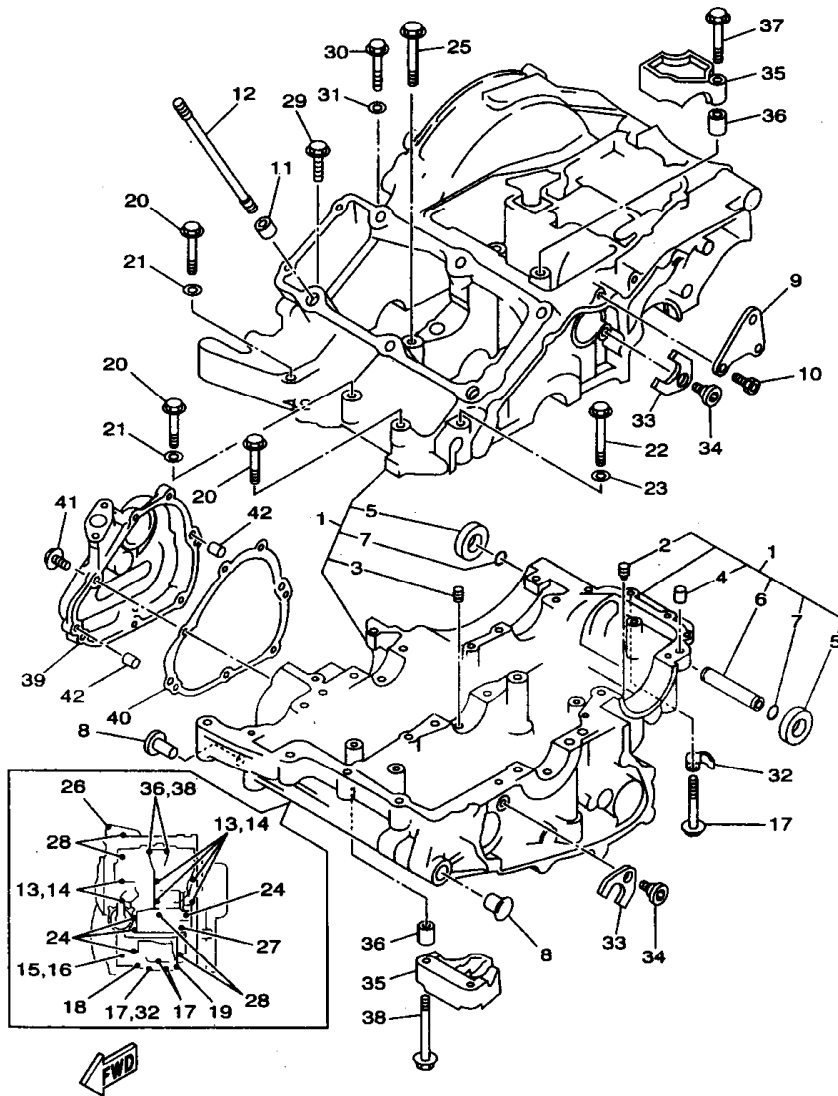

4TX1351-6120

REF. NO.	PART NO.	DESCRIPTION	4TX3	5AR2	REMARKS
26	95814-08050	BOLT, FLANGE	1		
	95817-08050	BOLT, FLANGE		1	
27	95817-08070	BOLT, FLANGE	1	1	
28	95817-08075	BOLT, FLANGE	4	4	
29	95817-06025	BOLT, FLANGE	1	1	
30	95814-08040	BOLT, FLANGE	1		
	95817-06040	BOLT, FLANGE		1	
31	90201-066F0	WASHER, PLATE	1	1	
32	90465-08341	CLAMP	1	1	
33	3LD-15191-00	PLATE	2	2	
34	90149-06285	SCREW	2	2	
35	3LD-15118-00	HOLDER	2	2	
36	99530-08016	PIN, DOWEL	4	4	
37	95817-06045	BOLT, FLANGE	2	2	
38	95817-06070	BOLT, FLANGE	2	2	
39	3VD-15416-10	COVER, OIL PUMP	1	1	
40	3VD-15456-00	GASKET, OIL PUMP COVER 1	1	1	
41	95024-06020	BOLT, FLANGE	7	7	
42	99530-08012	PIN, DOWEL	2	2	

FIG. 13 CRANKCASE COVER 1

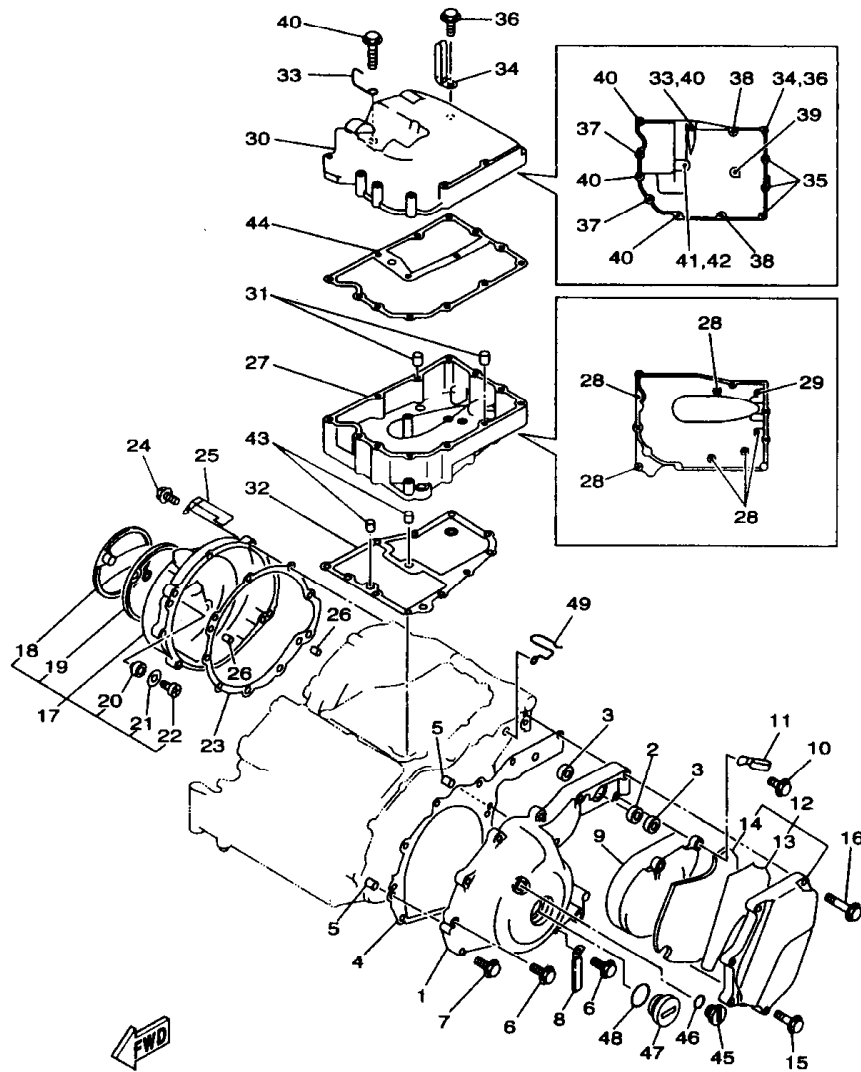

4TX1351-6130

REF. NO.	PART NO.	DESCRIPTION	4TX3	5AR2	REMARKS
1	3VD-15411-11	COVER, CRANKCASE 1	1	1	
2	93317-21236	BEARING	1	1	
3	93109-12053	OIL SEAL (SDO 12/18/4-1)	2	2	
4	3VD-15451-00	GASKET, CRANKCASE COVER 1	1	1	
5	99530-08012	PIN, DOWEL	2	2	
6	95024-06025	BOLT, FLANGE	8	8	
7	90105-06456	BOLT, WASHER BASED	1	1	
8	90465-08127	CLAMP	1	1	
9	3LD-15418-00	COVER, CHAIN CASE	1	1	
10	95027-06025	BOLT, FLANGE	2	2	
11	90465-08122	CLAMP	1	1	
12	3VD-15420-01	CRANKCASE COVER ASSY 2	1	1	
13	3VD-15326-00	.DAMPER, ENGINE MOUNT 2	1	1	
14	3VD-15335-00	.DAMPER 3	1	1	
15	95024-06030	BOLT, FLANGE	1	1	
16	95024-06055	BOLT, FLANGE	4	4	
17	4UN-15430-00	CRANKCASE COVER ASSY 3	1	1	
18	3VD-15417-01	.COVER, CAP	1	1	
19	3LD-15449-00	.RING, RUBBER	1	1	
20	1JK-15486-00	.GROMMET	2	2	
21	90209-05279	.WASHER	2	2	
22	98507-05010	.SCREW, PAN HEAD	2	2	
23	4NX-15462-01	GASKET, CRANKCASE COVER 3	1	1	
24	95024-06025	BOLT, FLANGE	9	9	
25	90465-15384	CLAMP	1	1	
26	99530-08012	PIN, DOWEL	2	2	
27	4UN-15425-00	COVER, GENERATOR 2	1	1	

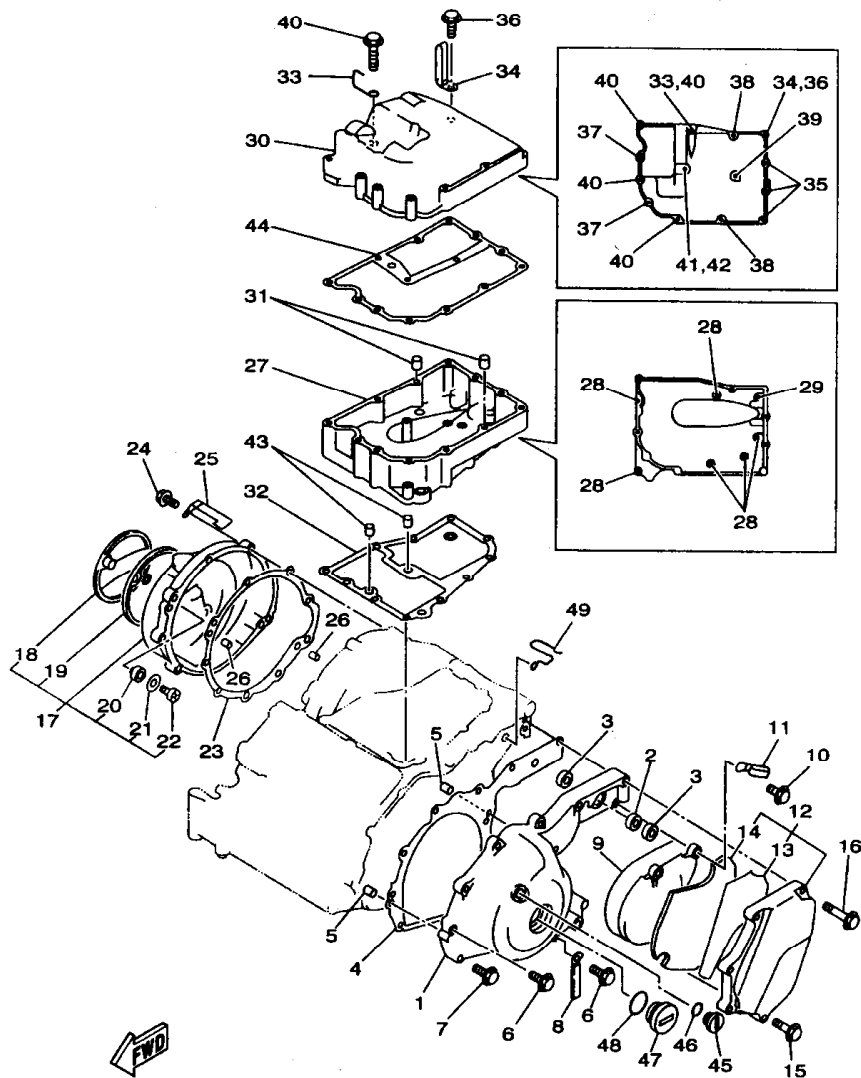

4TX1351-6130

FIG. 13 CRANKCASE COVER 1

REF. NO.	PART NO.	DESCRIPTION	4TX3	5AR2	REMARKS
28	95027-06035	BOLT, FLANGE	6	6	
29	95880-06035	BOLT, FLANGE	1	1	
30	4UN-15426-00	COVER, OIL PUMP 2	1	1	
31	99530-08012	PIN, DOWEL	2	2	
32	3VD-15463-00	GASKET, CARBURETOR COVER 2	1	1	
33	90462-20223	CLAMP	1	1	
34	90461-10136	CLAMP	1	1	
35	95024-06035	BOLT, FLANGE	3		
	95027-06035	BOLT, FLANGE		3	
36	95880-06035	BOLT, FLANGE	1	1	
37	95024-06045	BOLT, FLANGE	2		
	95027-06045	BOLT, FLANGE		2	
38	95024-06055	BOLT, FLANGE	2		
	95027-06055	BOLT, FLANGE		2	
39	90105-06131	BOLT, WASHER BASED	1	1	
40	95024-06110	BOLT, FLANGE	4		
	95027-06110	BOLT, FLANGE		4	
41	91317-06160	BOLT	1	1	
42	90201-06045	WASHER, PLATE	1	1	
43	99530-10114	PIN, DOWEL	2	2	
44	4NX-15461-00	GASKET, CRANKCASE COVER 2	1	1	
45	90340-14151	PLUG, STRAIGHT SCREW	1	1	
46	93210-14369	O-RING	1	1	
47	90340-32116	PLUG, STRAIGHT SCREW	1	1	
48	93210-32172	O-RING	1	1	
49	90465-20342	CLAMP	1	1	

FIG. 14 STARTER CLUTCH

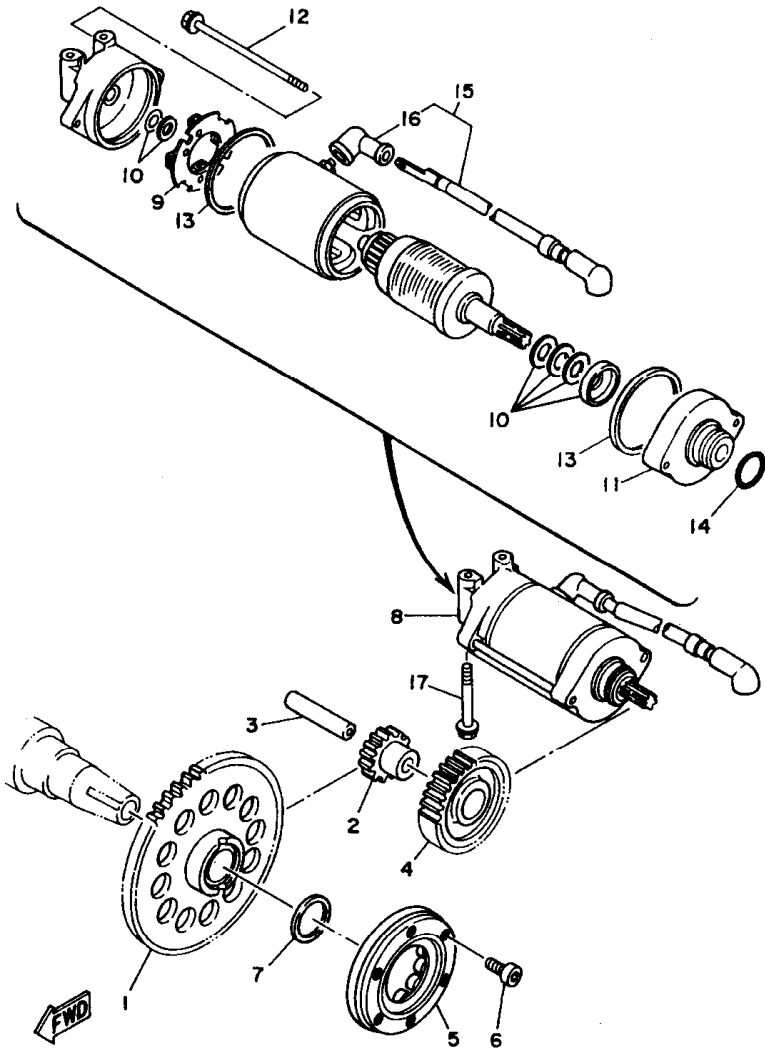

3LD1351-9140

REF. NO.	PART NO.	DESCRIPTION	4TX3	5AR2	REMARKS
1	4NX-15515-00	GEAR 3	1	1	
2	3LD-15517-00	GEAR, IDLER 2	1	1	
3	26H-15521-00	SHAFT 1	1	1	
4	3LD-15512-00	GEAR, IDLER 1	1	1	
5	3LD-15590-02	STARTER ONE-WAY ASSY	1	1	

6	91317-06018	BOLT	3	3	
7	90201-301P3	WASHER, PLATE	1	1	
8	3LD-81800-00	STARTING MOTOR ASSY	1	1	
9	3AJ-81801-00	.BRUSH SET	1	1	
10	3AJ-81809-00	.WASHER KIT	1	1	

11	3AJ-81830-00	.FRONT BRACKET ASSY	1	1	
12	3AJ-81826-00	.BOLT	2	2	
13	11H-81844-00	.GASKET	2	2	
14	1FK-81847-00	.O-RING	1	1	
15	3LD-81815-00	.CORD, STARTER MOTOR	1	1	
16	4G0-81871-00	.CAP	1	1	

17	95817-06050	BOLT, FLANGE	2	2	

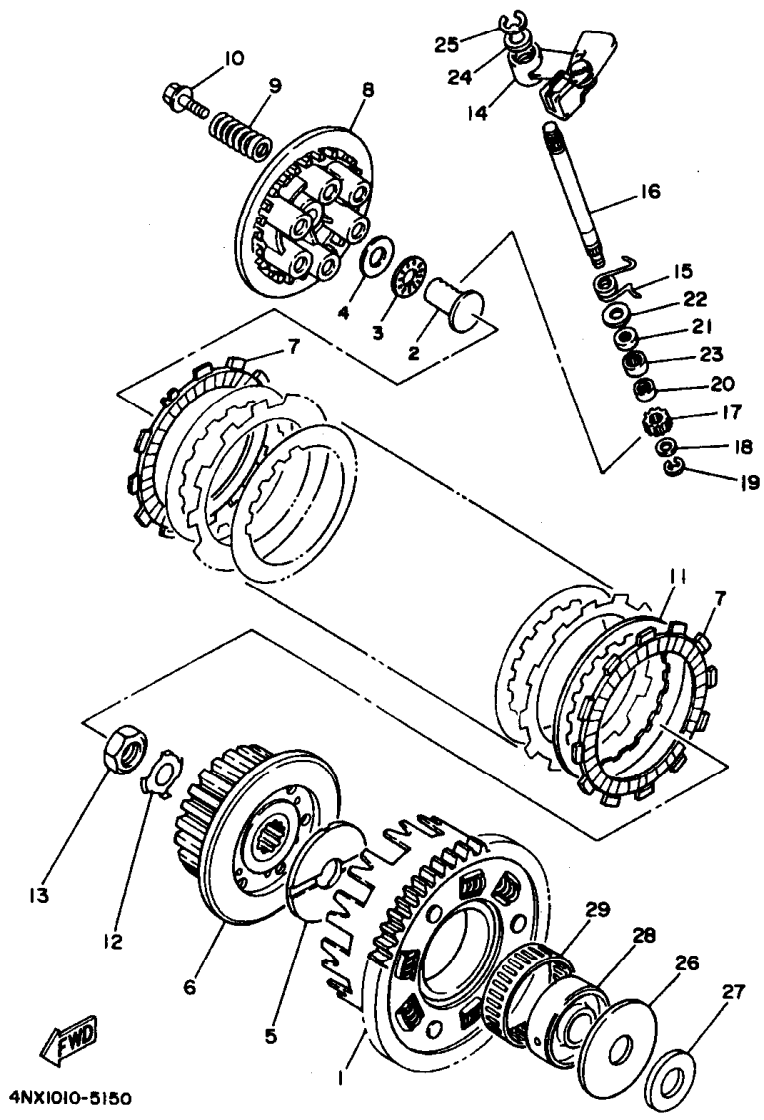

4NX1010-5150

FIG. 15 CLUTCH

REF. NO.	PART NO.	DESCRIPTION	4TX3	5AP2	REMARKS
1	4TX-16150-01	PRIMARY DRIVEN GEAR COMP.	1	1	
2	3LD-1637A-01	ROD PUSH ASSY	1	1	
3	93340-21505	BEARING	1	1	
4	90201-150U6	WASHER, PLATE	1	1	
5	4H7-16154-00	PLATE, THRUST 1	1	1	
<hr/>					
6	4TX-16371-00	BOSS, CLUTCH	1	1	
7	4TX-16321-00	PLATE, FRICTION	9	9	
8	3LD-16351-00	PLATE, PRESSURE 1	1	1	
9	90501-225A9	SPRING, COMPRESSION	6	6	
10	90159-06123	SCREW, WITH WASHER	6	6	
<hr/>					
11	3J2-16324-00	PLATE, CLUTCH 1	8	8	
12	90215-20231	WASHER, LOCK	1	1	
13	90170-20327	NUT	1	1	
14	4UN-16340-00	PUSH LEVER ASSY	1	1	
15	90508-167A3	SPRING, TORSION	1	1	
<hr/>					
16	3LD-16382-00	AXLE, PUSH LEVER	1	1	
17	3LD-16398-00	PINION, RELEAS	1	1	
18	92907-08600	WASHER, PLATE	1	1	
19	99001-07600	CIRCLIP	1	1	
20	93317-11020	BEARING	1	1	
<hr/>					
21	93102-12224	OIL SEAL	1	1	
22	90201-12163	WASHER, PLATE	1	1	
23	93315-11206	BEARING	1	1	
24	90201-10119	WASHER, PLATE	1	1	
25	99009-10400	CIRCLIP	1	1	
<hr/>					
26	3VD-16164-00	PLATE, THRUST 2	1	1	
27	3VD-16154-00	PLATE, THRUST 1	1	1	

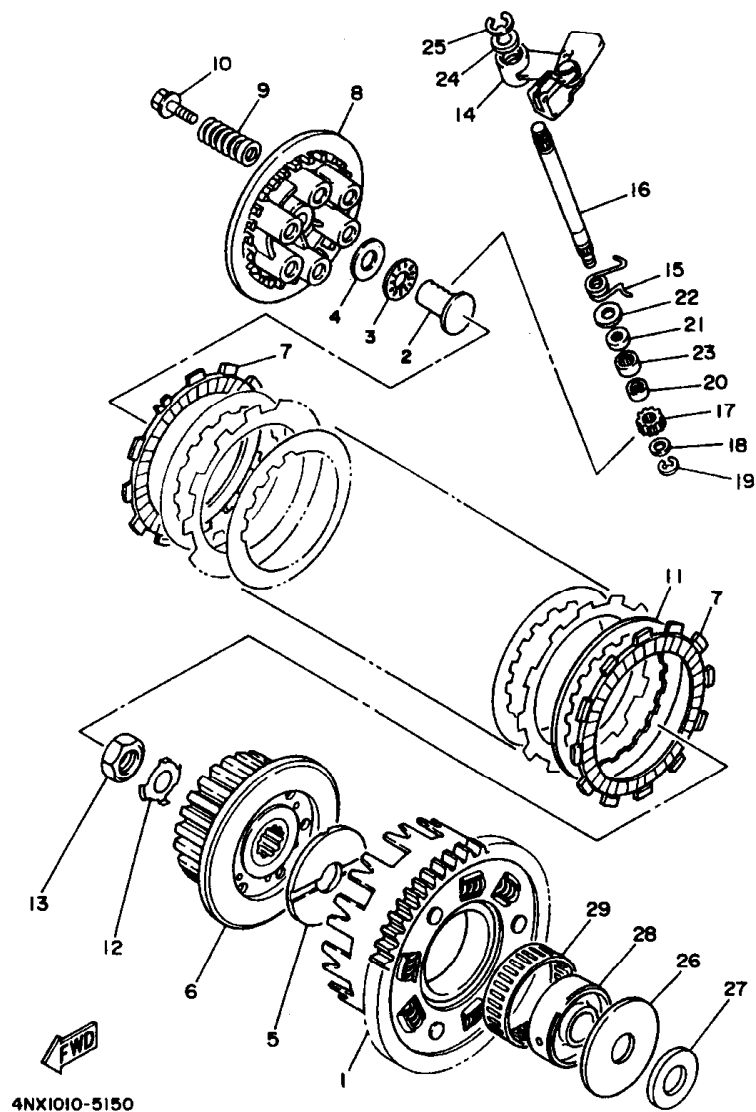
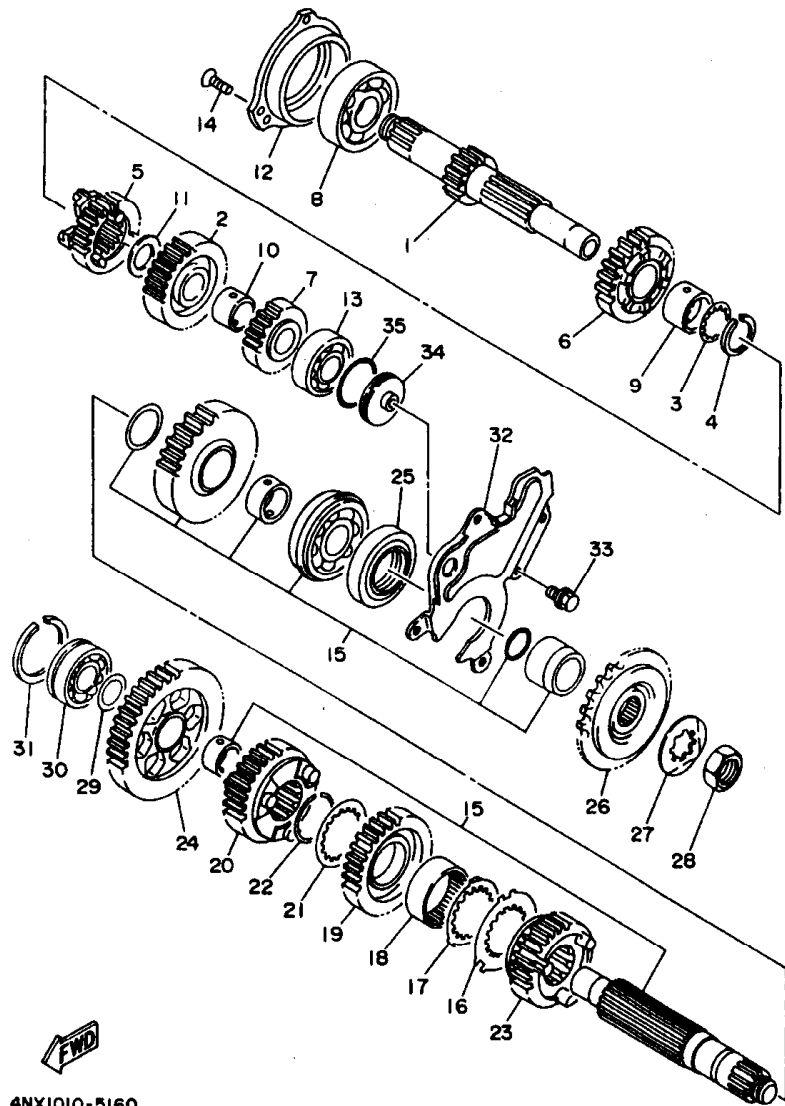

FIG. 15 CLUTCH

REF. NO.	PART NO.	DESCRIPTION	4TX3	5AP2	REMARKS
28	4NX-16181-00	SPACER 1	1	1	
29	93310-365B8	BEARING	1	1	

FIG. 16 TRANSMISSION



4NX1010-5160

REF. NO.	PART NO.	DESCRIPTION	4TX3	5AR2	REMARKS
1	3VD-17411-00	AXLE, MAIN (13T)	1	1	
2	2GH-17151-00	GEAR, 5TH PINION (27T)	1	1	
3	90209-21332	WASHER	1	1	
4	93440-25084	CIRCLIP	1	1	
5	4UN-17131-00	GEAR, 3RD PINION(21T)	1	1	
6	2GH-17141-00	GEAR, 4TH PINION (23T)	1	1	
7	3LD-17121-00	GEAR, 2ND PINION (20T)	1	1	
8	93306-30525	BEARING (B6305)	1	1	
9	90387-253M6	COLLAR	1	1	
10	90387-203M7	COLLAR	1	1	
11	90201-200K3	WASHER, PLATE	1	1	
12	3LD-15163-10	HOUSING, BEARING 1	1	1	
13	93306-20464	BEARING	1	1	
14	90149-06286	SCREW	3	3	
15	4NX-17402-00	DRIVE AXLE ASSY	1	1	
16	90209-29329	WASHER	1	1	
17	90209-28330	WASHER	1	1	
18	90387-2802W	COLLAR	1	1	
19	4UN-17231-00	GEAR, 3RD WHEEL(30T)	1	1	
20	4NX-17241-00	GEAR, 4TH WHEEL(27T)	1	1	
21	90209-28331	WASHER	1	1	
22	93440-31172	CIRCLIP	1	1	
23	4NX-17251-00	GEAR, 5TH WHEEL(28T)	1	1	
24	4TX-17211-00	GEAR, 1ST WHEEL (37T)	1	1	
25	93102-35459	OIL SEAL	1	1	
26	4AS-17460-00	SPROCKET, DRIVE(17T)	1	1	
27	90215-21290	WASHER, LOCK	1	1	

FIG. 16 TRANSMISSION

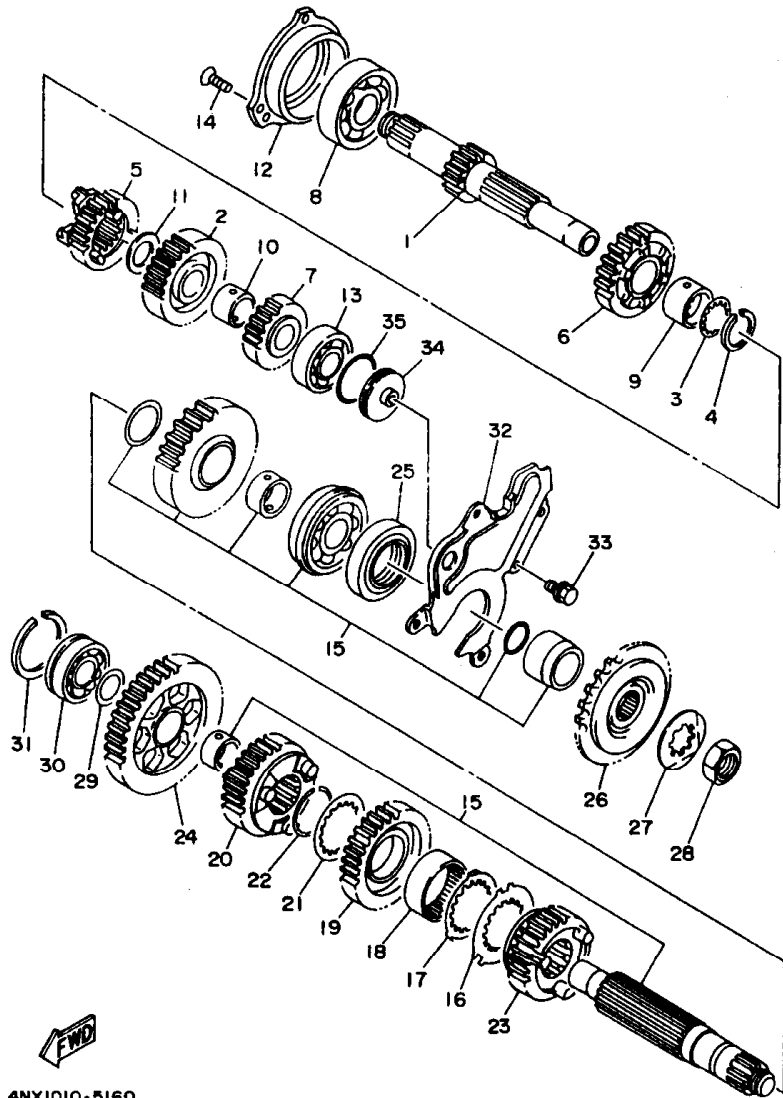

4NX1010-5160

REF. NO.	PART NO.	DESCRIPTION			REMARKS
			4TX3	5AR2	
28	90179-18667	NUT	1	1	
29	90201-20278	WASHER, PLATE	1	1	
30	93306-20455	BEARING	1	1	
31	93440-45144	CIRCLIP	1	1	
32	4NX-17471-00	PLATE, COVER	1	1	
33	95827-06012	BOLT, FLANGE	5	5	
34	3LD-15414-00	COVER, AIR CLEANER	1	1	
35	93210-33133	O-RING	1	1	

FIG. 17 SHIFT CAM. FORK

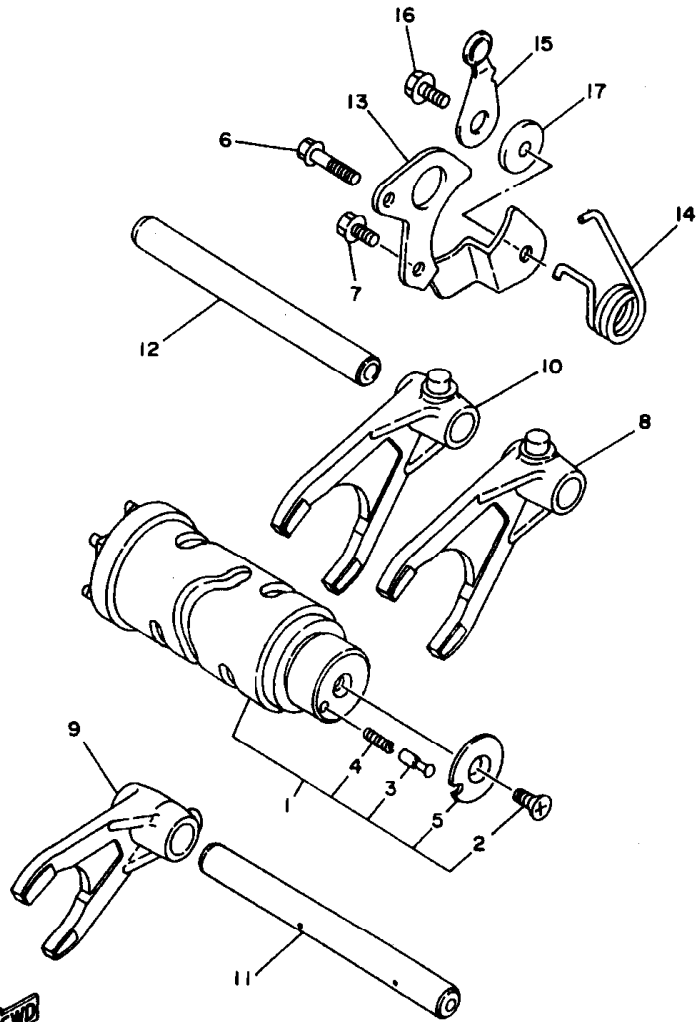

4NX1010-5170

REF. NO.	PART NO.	DESCRIPTION			REMARKS
			4TX3	5AR2	
1	3VD-18540-01	SHIFT CAM ASSY	1	1	
2	98707-05012	.SCREW, FLAT HEAD	1	1	
3	4UN-18542-00	.POINT, NEUTRAL	1	1	
4	90501-06022	.SPRING, COMPRESSION	1	1	
5	4UN-18566-00	.PLATE, SIDE 2	1	1	
6	90105-06597	BOLT, WASHER BASED	1	1	
7	90105-06397	BOLT, WASHER BASED	1	1	
8	3VD-18511-00	FORK, SHIFT 1	1	1	
9	3VD-18512-00	FORK, SHIFT 2	1	1	
10	3VD-18513-00	FORK, SHIFT 3	1	1	
11	4NX-18531-00	BAR, SHIFT FORK GUIDE 1	1	1	
12	4NX-18535-00	BAR, SHIFT FORK GUIDE 2	1	1	
13	3LD-18536-00	STOPPER, SHIFT BAR	1	1	
14	90508-297A4	SPRING, TORSION	1	1	
15	4NX-18140-00	STOPPER LEVER ASSY	1	1	
16	90105-06557	BOLT, WASHER BASED	1	1	
17	4NX-18175-00	SPACER	1	1	

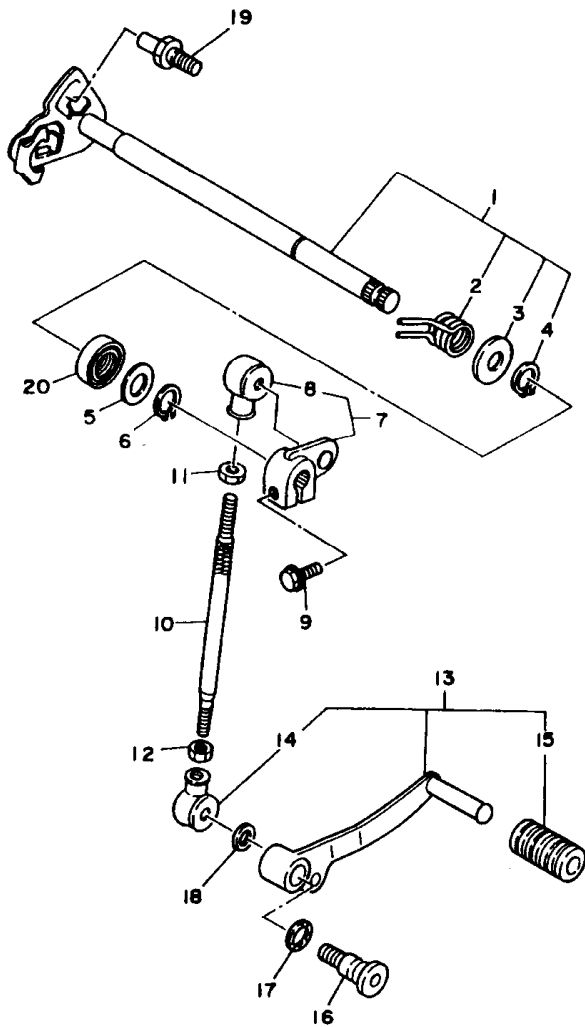

3VD1351-1180

FIG. 18 SHIFT SHAFT

REF. NO.	PART NO.	DESCRIPTION	4TX3	5AR2	REMARKS
1	3LD-18101-02	SHIFT SHAFT ASSY	1	1	
2	90508-32682	.SPRING, TORSION	1	1	
3	90201-191J4	.WASHER, PLATE	1	1	
4	99009-19400	.CIRCLIP	1	1	
5	90201-12575	WASHER, PLATE	1	1	
6	99001-10600	CIRCLIP	1	1	
7	3LD-18130-00	SHIFT SHAFT ASSY	1	1	
8	2H9-18154-00	.COVER, DUST	1	1	
9	95827-08020	BOLT, FLANGE	1	1	
10	3VD-18115-00	ROD, SHIFT	1	1	
11	90170-06228	NUT(COUNTER CLOCKWISE)	1	1	
12	95304-06700	NUT	1	1	
13	3VD-18110-10	SHIFT PEDAL ASSY	1	1	
14	2H9-18154-00	.COVER, DUST	1	1	
15	132-18113-01	.COVER, SHIFT PEDAL	1	1	
16	2YK-27434-01	BOLT	1	1	
17	90206-12074	WASHER, WAVE	1	1	
18	90201-08326	WASHER, PLATE	1	1	
19	4G0-18127-00	STOPPER, SCREW	1	1	
20	93101-12004	OIL SEAL	1	1	

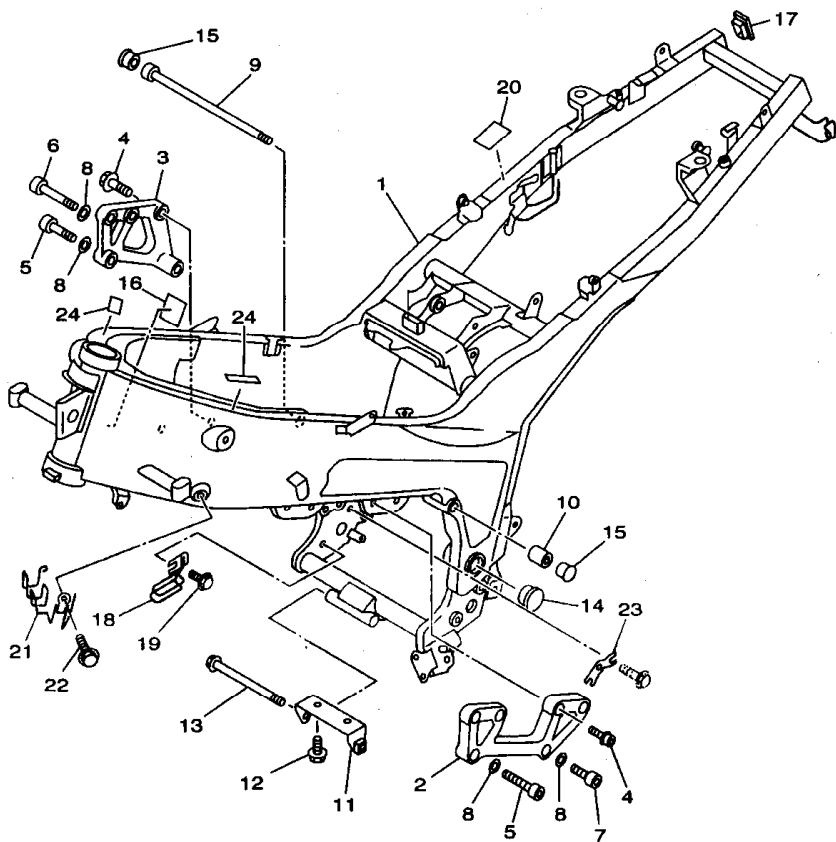

FWD
4TX3351-8190

FIG. 19 FRAME

REF. NO.	PART NO.	DESCRIPTION	4TX3	5AP2	REMARKS
1	4TX-21110-01-35	FRAME COMP.	1	1	SL
2	3VD-21411-10-35	BRACKET, ENGINE 1	1	1	SL
3	4TX-21419-00-35	BRACKET, ENGINE 2	1	1	SL
4	90109-083G1	BOLT	7	7	
5	91314-10045	BOLT	2	2	
6	91314-10060	BOLT	1	1	
7	91314-10025	BOLT	1	1	
8	90201-10430	WASHER, PLATE	4	4	
9	90110-10229	BOLT, HEXAGON SOCKET HEAD	1	1	
10	90179-10377	NUT	1	1	
11	3VD-21489-00	BRACKET, ENGINE LOWER	1	1	
12	90105-08752	BOLT, WASHER BASED	2	2	
13	90105-10328	BOLT, WASHER BASED	1	1	
14	4TX-2135F-01	COVER	2	2	
15	3LD-2143A-00	CAP	2	2	
16	11H-21747-00	DAMPER	1	1	
17	3VD-2143A-00	CAP	2	2	
18	3VD-21164-00	HOLDER, CABLE	1	1	
19	95807-06010	BOLT, FLANGE	1	1	
20	3YL-12232-00	DAMPER	1	1	
21	4TX-21161-00	HOLDER, CABLE	1	1	
22	90105-06446	BOLT, WASHER BASED	1	1	
23	4TX-2148U-00	BRACKET 1	1	1	
24	4KB-21268-00	SEAL	2	2	

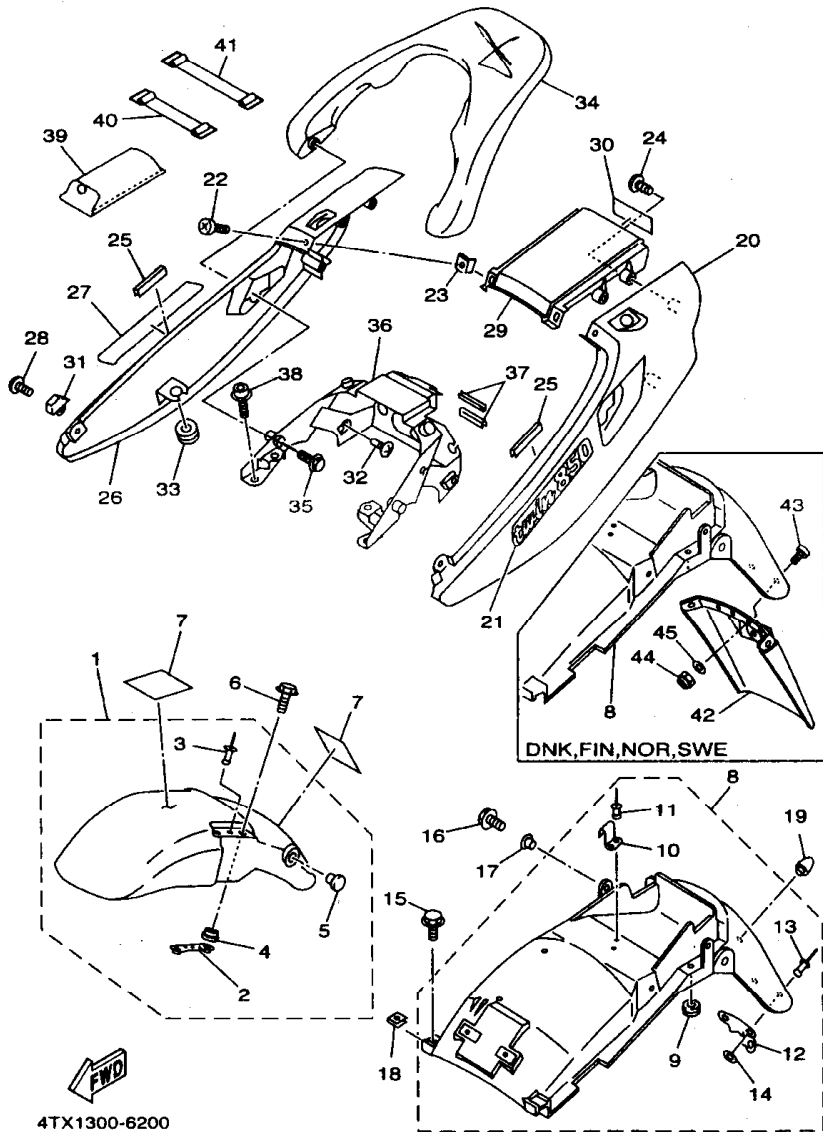

4TX1300-6200

FIG. 20 FENDER

REF. NO.	PART NO.	DESCRIPTION	4TX3	5AR2	REMARKS
1	3VD-Y2151-10-4B	FRONT FENDER COMP.	1	1	UR BL2
	3VD-Y2151-10-P6	FRONT FENDER COMP.	1	1	UR DRYC1
	3VD-Y2151-10-P8	FRONT FENDER COMP.	1	1	UR DPBMC
2	3GM-21512-00	.BRACKET, FENDER	2	2	
3	90267-32071	.RIVET, BLIND	2	2	
4	90387-065T2	.COLLAR	4	4	
5	90338-12192	.PLUG	1	1	
6	90105-06477	BOLT, WASHER BASED	4	4	
7	3FY-21575-01	SEAL 1	1	1	
8	3VD-Y2161-01	REAR FENDER COMP.	1		UR
	3VD-Y2161-G0	REAR FENDER COMP.	1	1	UR FOR DNK, FIN, NOR, SWE
9	90480-10258	.GROMMET	2	2	
10	3VD-21366-00	.HOOK, TOOL BAND	1	1	
11	90267-40073	.RIVET, BLIND	2	2	
12	3HE-85132-01	.BRACKET, REFLECTOR 1	1		EXCEPT FOR DNK, FIN, NOR, SWE
13	90267-40035	.RIVET, BLIND	2		EXCEPT FOR DNK, FIN, NOR, SWE
14	90201-04018	.WASHER, PLATE	2		EXCEPT FOR DNK, FIN, NOR, SWE
15	95027-06010	BOLT, FLANGE	2	2	
16	95027-06020	BOLT, FLANGE	2	2	
17	90387-064J1	COLLAR	2	2	
18	90183-06023	NUT, SPRING	2	2	
19	2MG-21639-00	DAMPER 2	1	1	
20	4TX-2471K-00-4B	COVER, TAIL 1	1	1	UR BL2
	4TX-2471K-00-P3	COVER, TAIL 1	1	1	UR DRYC1
	4TX-2471K-00-P4	COVER, TAIL 1	1	1	UR DPBMC
21	4TX-21781-30	EMBLEM 1	1	1	UR FOR BL2
	4TX-21781-40	EMBLEM 1	1	1	UR FOR DRYC1

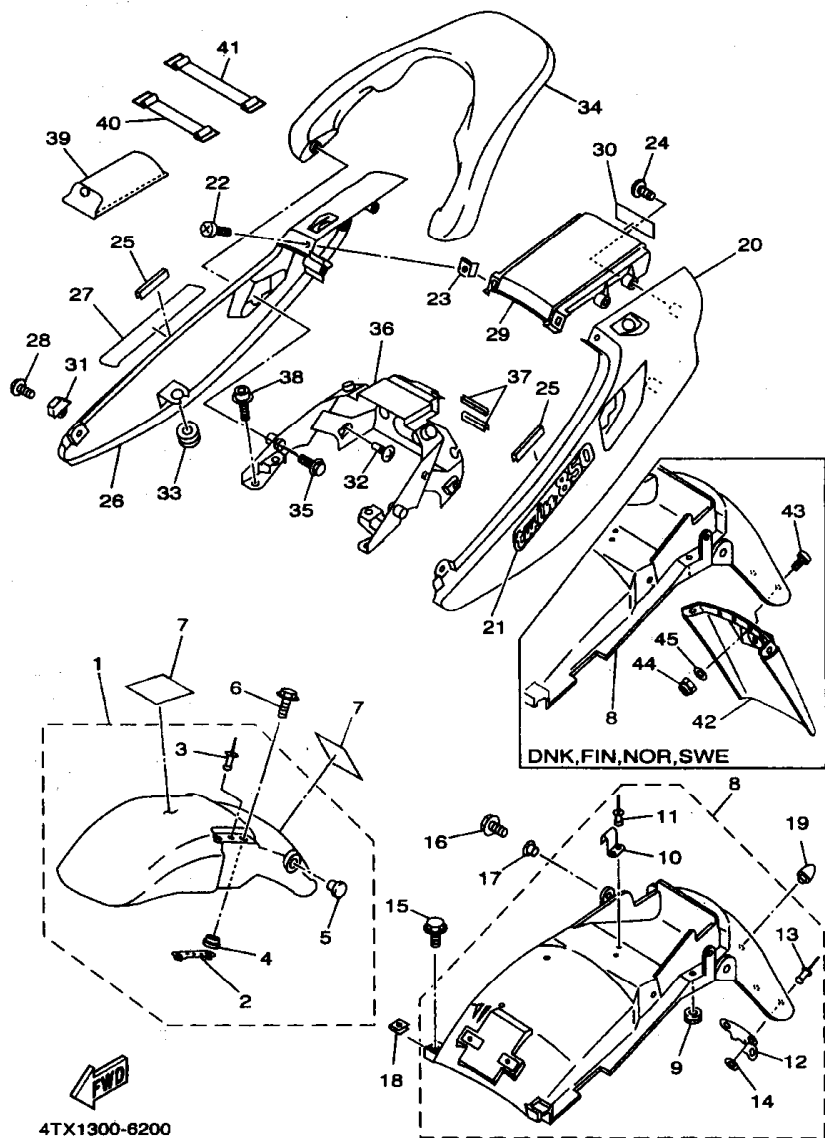

4TX1300-6200

FIG. 20 FENDER

REF. NO.	PART NO.	DESCRIPTION	4TX3	5APZ	REMARKS
21	4TX-21781-60	EMBLEM 1	1	1	UR FOR DPBMC
22	98907-05010	SCREW, BIND	2	2	
23	90183-05024	NUT, SPRING	2	2	
24	97707-50012	SCREW, TAPPING	4	4	
25	4KB-21268-00	SEAL	2	2	
26	4TX-2472K-00-4B	COVER, TAIL 2	1	1	UR BL2
	4TX-2472K-00-P3	COVER, TAIL 2	1	1	UR DRYC1
	4TX-2472K-00-P4	COVER, TAIL 2	1	1	UR DPBMC
27	4TX-21781-30	EMBLEM 1	1	1	UR FOR BL2
	4TX-21781-40	EMBLEM 1	1	1	UR FOR DRYC1
	4TX-21781-60	EMBLEM 1	1	1	UR FOR DPBMC
28	92017-06012	BOLT, BUTTON HEAD	2	2	
29	4TX-21651-00-4B	COVER, REAR FENDER	1	1	UR BL2
	4TX-21651-00-P3	COVER, REAR FENDER	1	1	UR DRYC1
	4TX-21651-00-P4	COVER, REAR FENDER	1	1	UR DPBMC
30	99236-00080	EMBLEM, YAMAHA	1	1	UR FOR BL2, DPBMC
	99234-00080	EMBLEM, YAMAHA	1	1	UR FOR DRYC1
31	4TX-2161A-00	BRACKET 3	2	2	
32	97707-50012	SCREW, TAPPING	4	4	
33	90480-12550	GROMMET	2	2	
34	3VD-21645-00-4B	STAY, REAR	1	1	UR BL2
	3VD-21645-00-P7	STAY, REAR	1	1	UR DRYC1
	3VD-21645-00-P9	STAY, REAR	1	1	UR DPBMC
35	95827-08040	BOLT, FLANGE	4	4	
36	4TX-2117E-00	BRACKET, TAILLIGHT	1	1	
37	46X-21269-00	SEAL	2	2	
38	90109-085E2	BOLT	4	4	

FIG. 20 FENDER

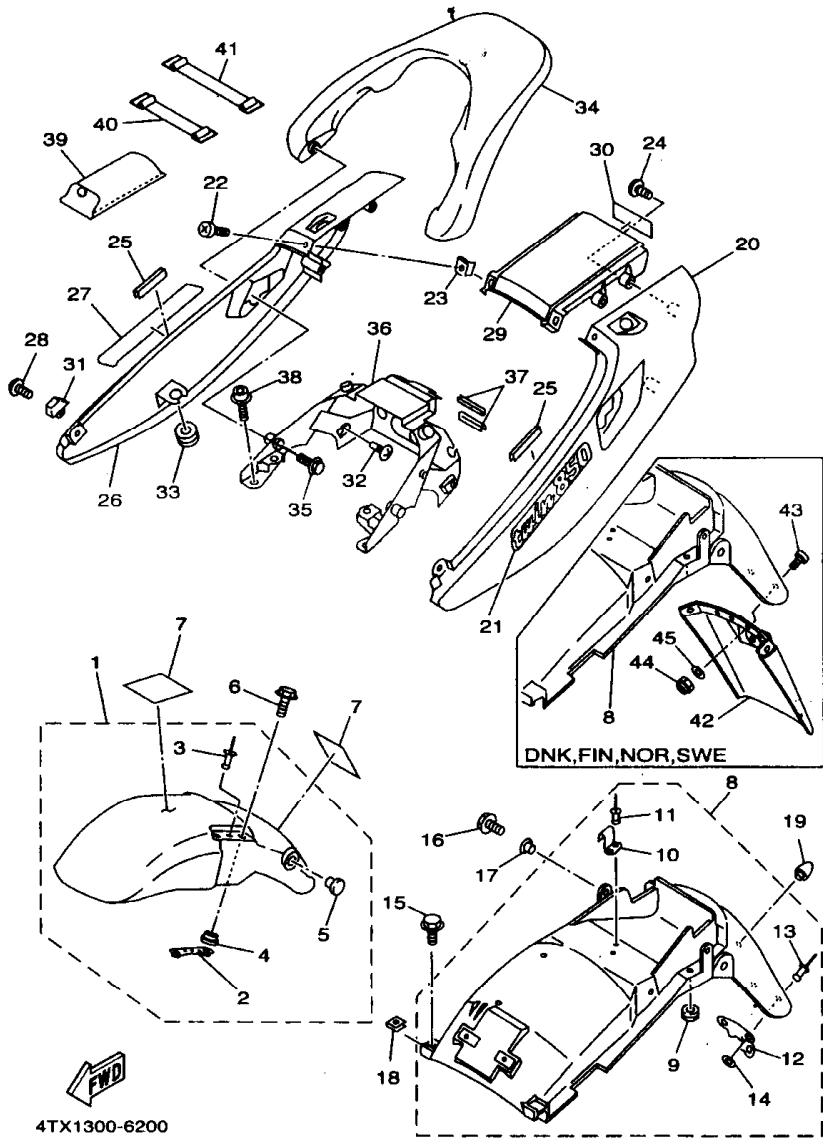

REF. NO.	PART NO.	DESCRIPTION	4TX3	5AR2	REMARKS
39	4TX-28100-00	TOOL KIT	1	1	
40	116-82131-00	BAND, BATTERY	1	1	
41	133-82131-00	BAND, BATTERY	1	1	
42	3LD-21621-01	FLAP	1	1	FOR DNK, FIN, NOR, SWE
43	90149-04278	SCREW	4	4	FOR DNK, FIN, NOR, SWE
44	95607-04100	NUT, U	4	4	FOR DNK, FIN, NOR, SWE
45	90201-047A2	WASHER, PLATE	4	4	FOR DNK, FIN, NOR, SWE

FIG. 21 SIDE COVER

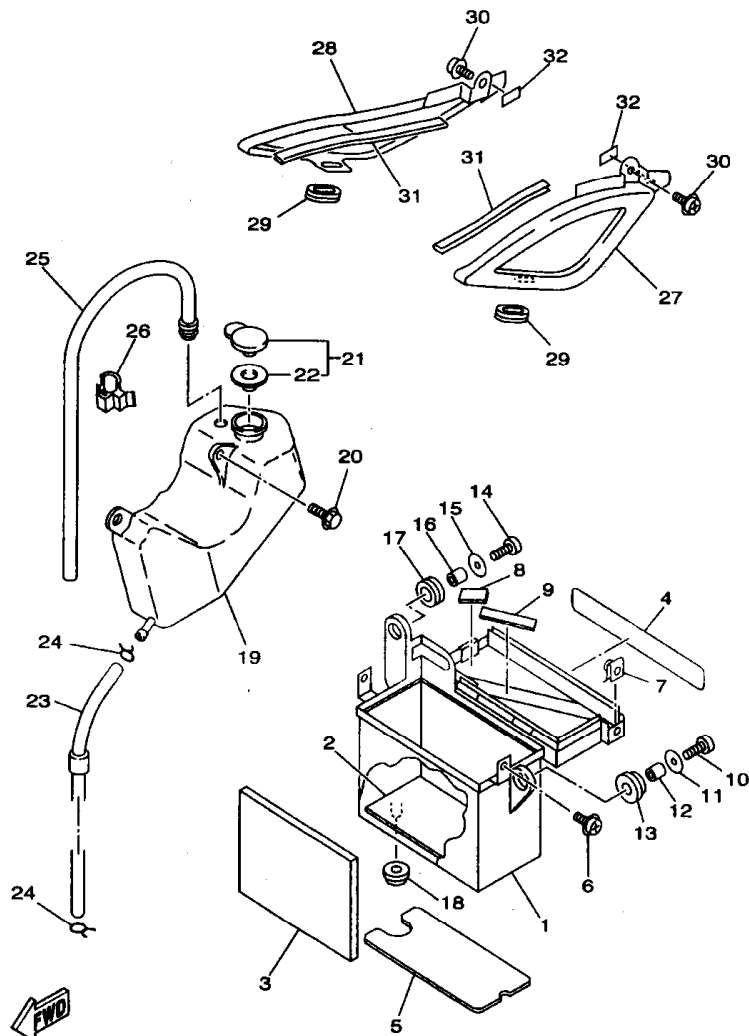

4TX1351-6210

REF. NO.	PART NO.	DESCRIPTION	4TX3	5AP2	REMARKS
1	4TX-2177G-00	BOX, BATTERY	1	1	
2	3Y6-21747-00	DAMPER	1	1	
3	4TX-21732-00	SEAL 1	1	1	
4	4TX-21735-00	SEAL 2	1	1	
5	4TX-2173M-00	SEAL 3	1	1	
6	90159-06093	SCREW, WITH WASHER	2	2	
7	90183-06053	NUT, SPRING	2	2	
8	51Y-21639-00	DAMPER 2	1	1	
9	50M-21638-00	DAMPER 1	1	1	
10	91317-06025	BOLT	1	1	
11	90201-06071	WASHER, PLATE	1	1	
12	90560-07007	SPACER	1	1	
13	90480-16404	GROMMET	1	1	
14	91317-06025	BOLT	1	1	
15	90201-06071	WASHER, PLATE	1	1	
16	90387-07674	COLLAR	1	1	
17	90480-16233	GROMMET	1	1	
18	90480-13369	GROMMET	1	1	
19	3VD-21871-00	TANK, RECOVERY	1	1	
20	90119-06056	BOLT, WITH WASHER	2	2	
21	1AA-21815-00	CAP	1	1	
22	1AA-21874-00	.GASKET	1	1	
23	90445-086J6	HOSE	1	1	
24	90467-08075	CLIP	2	2	
25	3VD-21816-00	PIPE 1	1	1	
26	90464-10190	CLAMP	1	1	
27	4TX-21711-00	COVER, SIDE 1	1	1	

FIG. 21 SIDE COVER

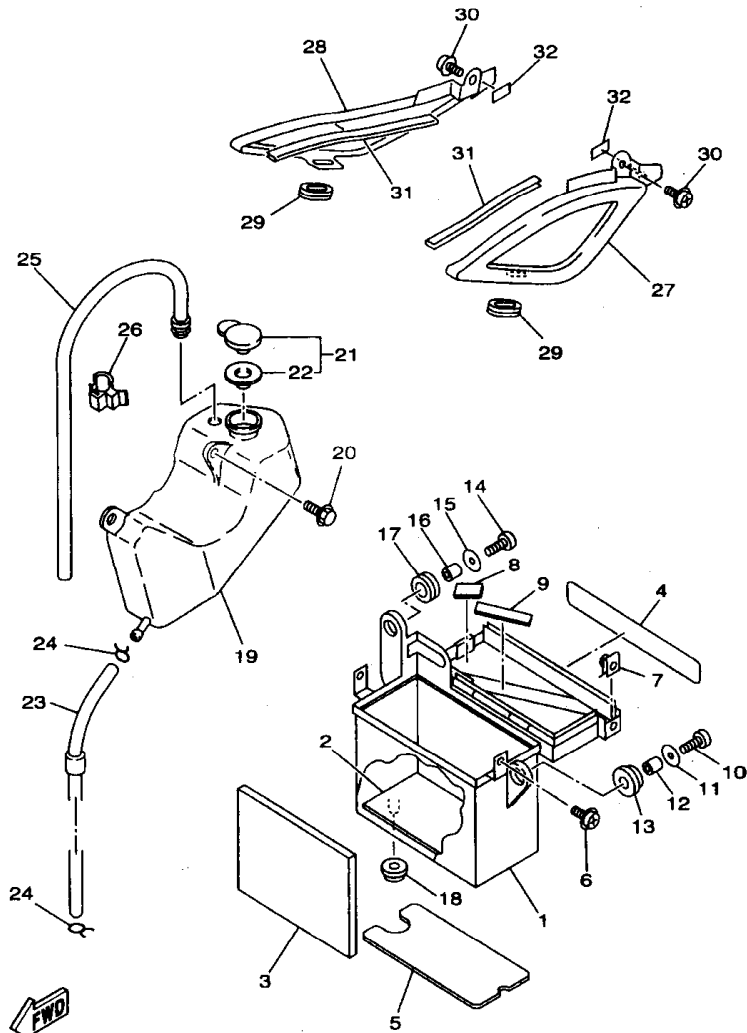

4TX1351-6210

REF. NO.	PART NO.	DESCRIPTION	4TX3	5AR2	REMARKS
28	4TX-21721-00	COVER, SIDE 2	1	1	
29	90480-01603	GROMMET	2	2	
30	90159-06059	SCREW, WITH WASHER	2	2	
31	4TX-21652-01	PROTECTOR	2	2	
32	51Y-21639-00	DAMPER 2	4	4	

FIG. 22 REAR ARM

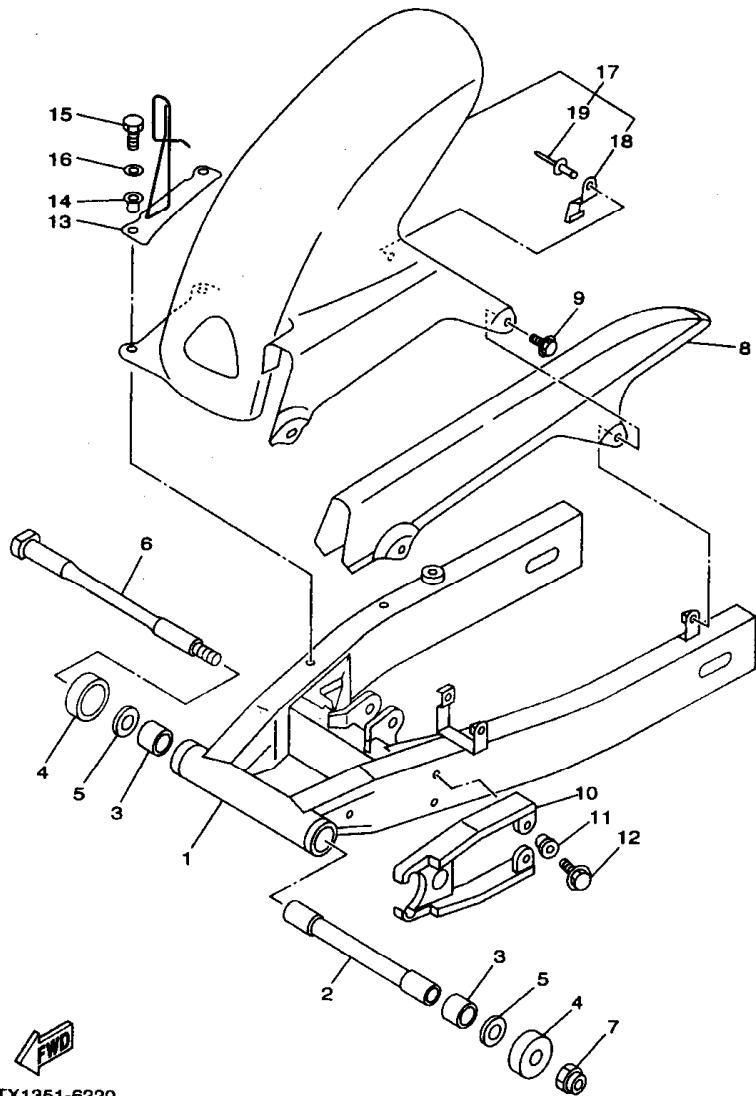

4TX1351-6220

REF. NO.	PART NO.	DESCRIPTION	4TX3	5AR2	REMARKS
1	4TX-22110-00	REAR ARM COMP.	1	1	
2	33M-22184-00	BUSH	1	1	
3	93320-32403	BEARING	2	2	
4	4X7-22129-00	COVER, THRUST 2	2	2	
5	90201-161J3	WASHER, PLATE	2	2	
6	46X-22141-00	SHAFT, PIVOT	1	1	
7	90185-14112	NUT, SELF-LOCKING	1	1	
8	3VD-22311-00	CASE, CHAIN	1	1	
9	90119-06044	BOLT, WITH WASHER	2	2	
10	3VD-22151-00	SEAL, GUARD	1	1	
11	90387-06681	COLLAR	3	3	
12	90119-06108	BOLT, WITH WASHER	3	3	
13	3VD-25875-01	HOLDER, BRAKE HOSE 1	1	1	
14	90387-064J1	COLLAR	2	2	
15	97007-06025	BOLT	2	2	
16	92907-06600	WASHER, PLATE	2	2	
17	3VD-W2165-00	FENDER COMP, REAR TIRE	1	1	
18	3VD-2164F-00	.STAY 1	1	1	
19	90267-40105	.RIVET, BLIND	1	1	

FIG. 23 REAR SUSPENSION

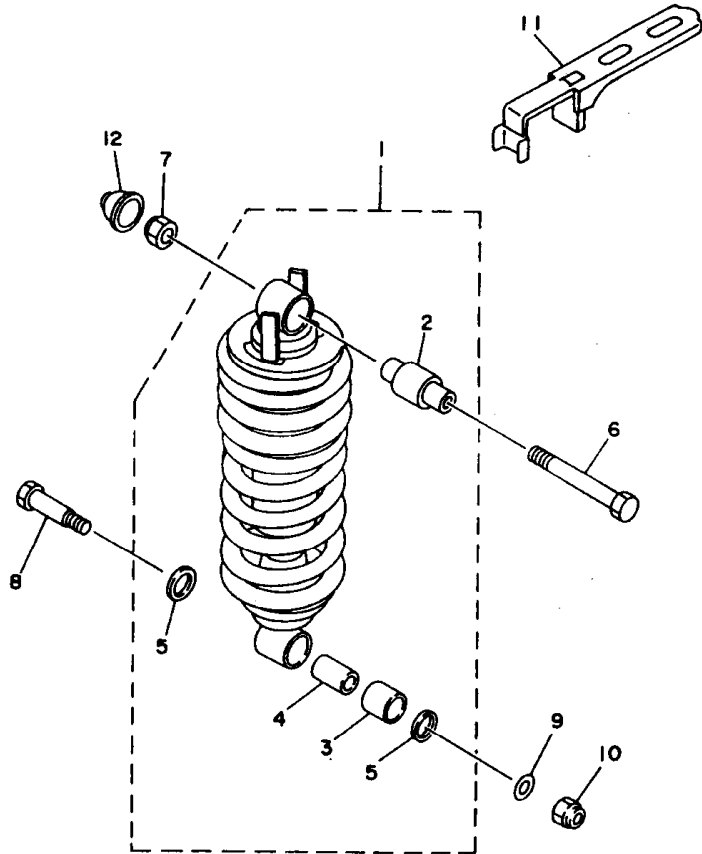

REF. NO.	PART NO.	DESCRIPTION			REMARKS
			4TX3	5AR2	
1	4TX-22210-00	SHOCK ABSORBER ASSY, REAR	1	1	
2	3VD-22216-00	.BUSH, REAR SHOCK ABSORBER	1	1	
3	90384-18190	.BUSH, BIMETAL FORMED	1	1	
4	90387-127X0	.COLLAR	1	1	
5	93109-18020	.OIL SEAL	2	2	
6	90109-125F1	BOLT	1	1	
7	95607-12100	NUT, U	1	1	
8	90101-10659	BOLT	1	1	
9	90201-124G9	WASHER, PLATE	1	1	
10	95617-10100	NUT, U	1	1	
11	3VD-22464-00	KNOB, CONTROL	1	1	
12	10V-83365-00	CAP	1	1	

4TX1351-6230

FIG. 24 STEERING

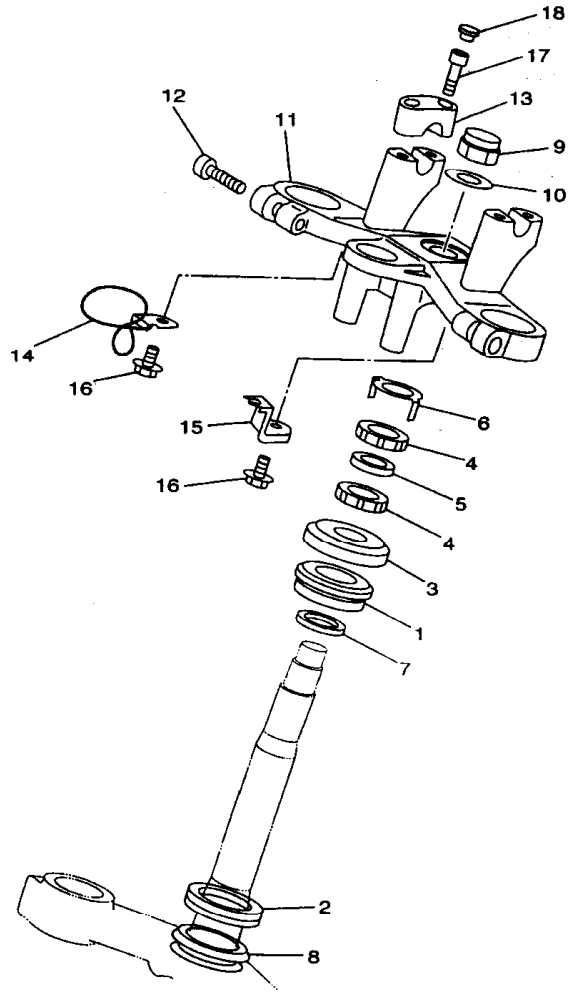

4TX1351-6240

REF. NO.	PART NO.	DESCRIPTION	4TX3	5AP2	REMARKS
1	93399-99931	BEARING	1	1	
2	93399-99932	BEARING	1	1	
3	1W1-23416-00	COVER, BALL RACE 2	1	1	
4	90179-25033	NUT	2	2	
5	90202-26142	WASHER, PLATE	1	1	
6	26H-23418-01	WASHER, SPECIAL	1	1	
7	90202-24190	WASHER, PLATE	1	1	
8	3FV-23462-00	SEAL, STEERING	1	1	
9	90176-22081	NUT, CROWN	1	1	
10	90201-220T0	WASHER, PLATE	1	1	
11	4TX-23435-00	CROWN, HANDLE	1	1	
12	91314-08030	BOLT	2	2	
13	4H7-23441-00-P0	HOLDER, HANDLE UPPER	2	2	LGM1
14	4TX-23389-00	GUIDE, CABLE	1	1	
15	4TX-2637G-00	HOLDER, WIRE	1	1	
16	90105-06556	BOLT, WASHER BASED	2	2	
17	91314-08030	BOLT	4	4	
18	90338-08163	PLUG	4	4	

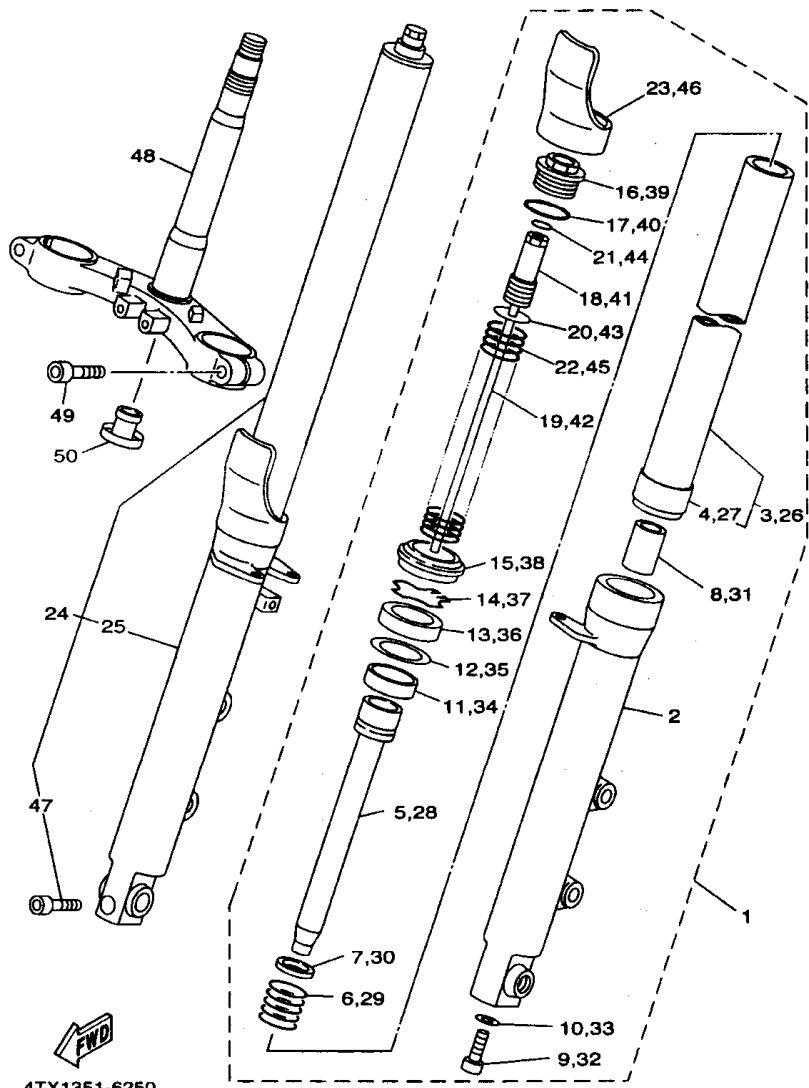
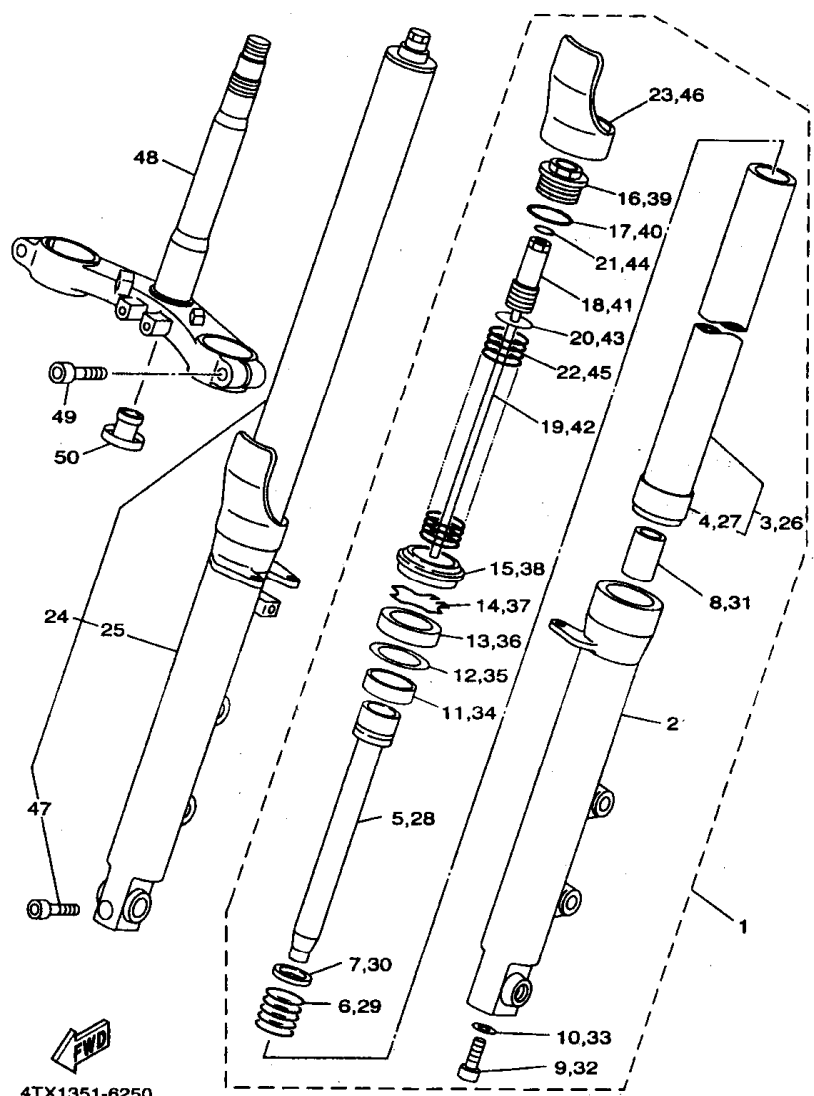

FIG. 25 FRONT FORK

REF. NO.	PART NO.	DESCRIPTION	4TX3	5AR2	REMARKS
1	4TX-23102-01	FRONT FORK ASSY (L.H)	1	1	
2	4TX-23126-01	.TUBE, OUTER (LEFT)	1	1	
3	4TX-23110-00	.INNER TUBE COMP.1	1	1	
4	4TX-23135-A0	.METAL, SLIDE 2	1	1	
5	4TX-23170-00	.CYLINDER COMP., FRONT FORK	1	1	
6	4TX-23151-00	.SPRING, REBOUND	1	1	
7	4TX-23157-00	.RING, PISTON	1	1	
8	4TX-23173-00	.SPINDLE, TAPER	1	1	
9	91317-10025	.BOLT	1	1	
10	90430-10171	.GASKET	1	1	
11	4TX-23125-A0	.METAL, SLIDE 1	1	1	
12	4TX-23115-00	.GUIDE, COVER UPPER	1	1	
13	4TX-23145-00	.OIL SEAL UK	1	1	
14	4TX-23156-00	.CLIP, OIL SEAL	1	1	
15	4TX-23144-00	.SEAL, DUST	1	1	
16	4TX-2311H-00	.FORK, BOLT	1	1	
17	93210-34504	.O-RING	1	1	
18	4TX-2311G-00	.BOLT, SPRINGADJUST	1	1	
19	4TX-2319K-00	.PLUNGER KIT	1	1	
20	4TX-2331L-00	.SEAT, SPRING UPPER	1	1	
21	93210-18N01	.O-RING	1	1	
22	4TX-23141-00	.SPRING, FRONT FORK	1	1	
23	4TX-2331G-00	.COVER	1	1	
24	4TX-23103-01	FRONT FORK ASSY (R.H)	1	1	
25	4TX-23136-01	.TUBE, OUTER (RIGHT)	1	1	
26	4TX-23110-00	.INNER TUBE COMP.1	1	1	
27	4TX-23135-A0	.METAL, SLIDE 2	1	1	

FIG. 25 FRONT FORK



REF. NO.	PART NO.	DESCRIPTION	4TX3	5AF2	REMARKS
28	4TX-23170-00	.CYLINDER COMP., FRONT FORK	1	1	
29	4TX-23151-00	.SPRING, REBOUND	1	1	
30	4TX-23157-00	.RING, PISTON	1	1	
31	4TX-23173-00	.SPINDLE, TAPER	1	1	
32	91317-10025	.BOLT	1	1	
33	90430-10171	.GASKET	1	1	
34	4TX-23125-A0	.METAL, SLIDE 1	1	1	
35	4TX-23115-00	.GUIDE, COVER UPPER	1	1	
36	4TX-23145-00	.OIL SEAL	1	1	
37	4TX-23156-00	.CLIP, OIL SEAL	1	1	
38	4TX-23144-00	.SEAL, DUST	1	1	
39	4TX-2311H-00	.FORK, BOLT	1	1	
40	93210-34504	.O-RING	1	1	
41	4TX-2311G-00	.BOLT, SPRINGADJUST	1	1	
42	4TX-2319K-00	.PLUNGER KIT	1	1	
43	4TX-2331L-00	.SEAT, SPRING UPPER	1	1	
44	93210-18N01	.O-RING	1	1	
45	4TX-23141-00	.SPRING, FRONT FORK	1	1	
46	4TX-2331G-00	.COVER	1	1	
47	91317-08040	.BOLT	1	1	
48	4TX-23340-00	UNDER BRACKET COMP.	1	1	
49	91317-10030	BOLT	2	2	
50	4KM-23123-01	COVER, LOWER 1	1	1	

FIG. 26 FUEL TANK

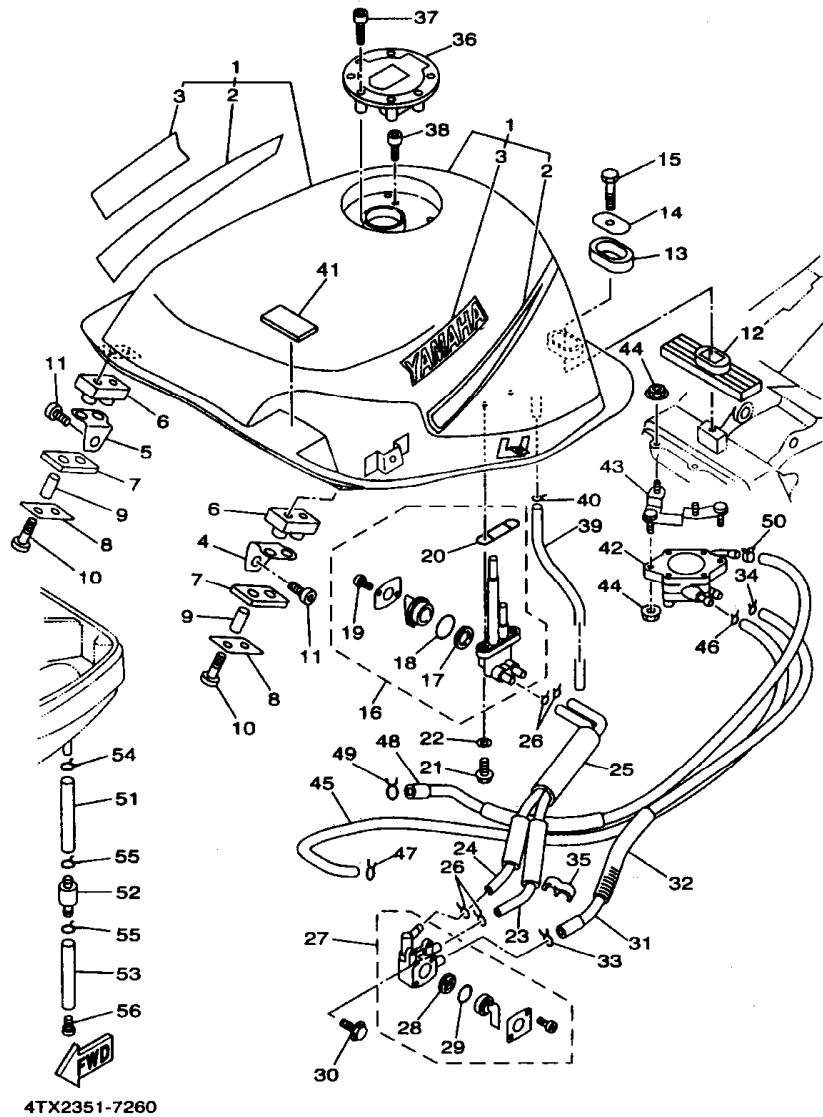

REF. NO.	PART NO.	DESCRIPTION	4TX3	5AR2	REMARKS
1	4TX-24110-10-05	FUEL TANK COMP.	1	1	UR SLAS FOR BL2
	4TX-24110-10-07	FUEL TANK COMP.	1	1	UR BL2 FOR DRYC1
	4TX-24110-10-08	FUEL TANK COMP.	1	1	UR BL2 FOR DPBMC
2	4TX-24240-30	.GRAPHIC SET	1	1	UR FOR BL2
	4TX-24240-40	.GRAPHIC SET	1	1	UR FOR DRYC1
	4TX-24240-60	.GRAPHIC SET	1	1	UR FOR DPBMC
3	99224-00140	.EMBLEM, YAMAHA	2	2	UR FOR BL2
	99226-00140	.EMBLEM, YAMAHA	2	2	UR FOR DRYC1, DPBMC
4	4TX-24191-00	BRACKET, FUEL TANK 1	1	1	
5	4TX-24192-00	BRACKET, FUEL TANK 2	1	1	
6	3VD-24181-00	DAMPER, LOCATING 1	2	2	
7	47X-24183-00	DAMPER, LOCATING 3	2	2	
8	47X-24186-00	WASHER, SPECIAL	2	2	
9	90387-06805	COLLAR	4	4	
10	92017-06035	BOLT, BUTTON HEAD	4	4	
11	90109-088A0	BOLT	2	2	
12	2GH-24184-00	DAMPER, LOCATING 4	1	1	
13	3Y6-24183-00	DAMPER, LOCATING 3	1	1	
14	12R-24186-00	WASHER, SPECIAL	1	1	
15	97007-08030	BOLT	1	1	
16	4TX-24510-00	FUEL COCK ASSY 2	1	1	
17	4DN-24523-00	.VALVE	1	1	
18	3AJ-24534-00	.SEAL, COCK	1	1	
19	98507-03008	.SCREW, PAN HEAD	2	2	
20	4X8-24512-00	.O-RING	1	1	
21	90149-06011	SCREW	2	2	
22	90202-05193	WASHER, PLATE	2	2	

FIG. 26 FUEL TANK

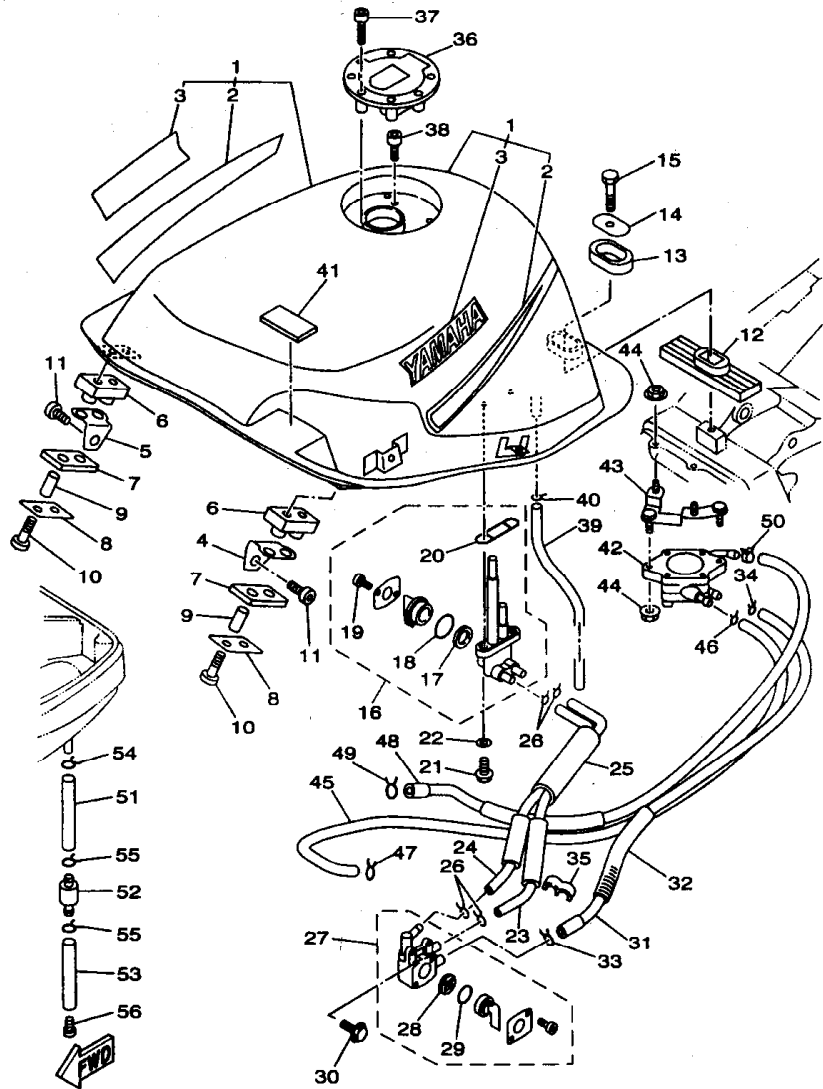

4TX2351-7260

REF. NO.	PART NO.	DESCRIPTION	4TX3	5AP2	REMARKS
23	4TX-24310-00	FUEL PIPE ASSY	1	1	
24	4TX-24311-00	PIPE, FUEL 1	1	1	
25	1JK-24327-00	PROTECTOR, PIPE	1	1	
26	90467-10008	CLIP	4	4	
27	3LN-24500-00	FUEL COCK ASSY 1	1	1	
28	3AJ-24523-00	.VALVE PACKING	1	1	
29	3AJ-24534-00	.SEAL, COCK	1	1	
30	95027-08010	BOLT, FLANGE	2	2	
31	4TX-24315-00	PIPE 5	1	1	
32	4TX-24326-00	PROTECTOR, PIPE	1	1	
33	90467-10008	CLIP	1	1	
34	90467-11106	CLIP	1	1	
35	90464-10075	CLAMP	1	1	
36	4FM-24602-00	CAP ASSY	1	1	
37	90110-05112	BOLT, HEXAGON SOCKET HEAD	3	3	
38	91317-05010	BOLT	1	1	
39	90445-106J2	HOSE	1	1	
40	90467-09006	CLIP	1	1	
41	30X-2139X-00	DAMPER	2	2	
42	4NX-13910-00	FUEL PUMP ASSY	1	1	
43	4TX-2452E-00	STAY	1	1	
44	95607-06200	NUT, SELF U-FLANGE	4	4	
45	4TX-13938-00	PIPE	1	1	
46	90467-08017	CLIP	1	1	
47	90467-08075	CLIP	1	1	
48	4TX-14294-00	HOSE	1	1	
49	90467-11106	CLIP	1	1	

FIG. 27 SEAT

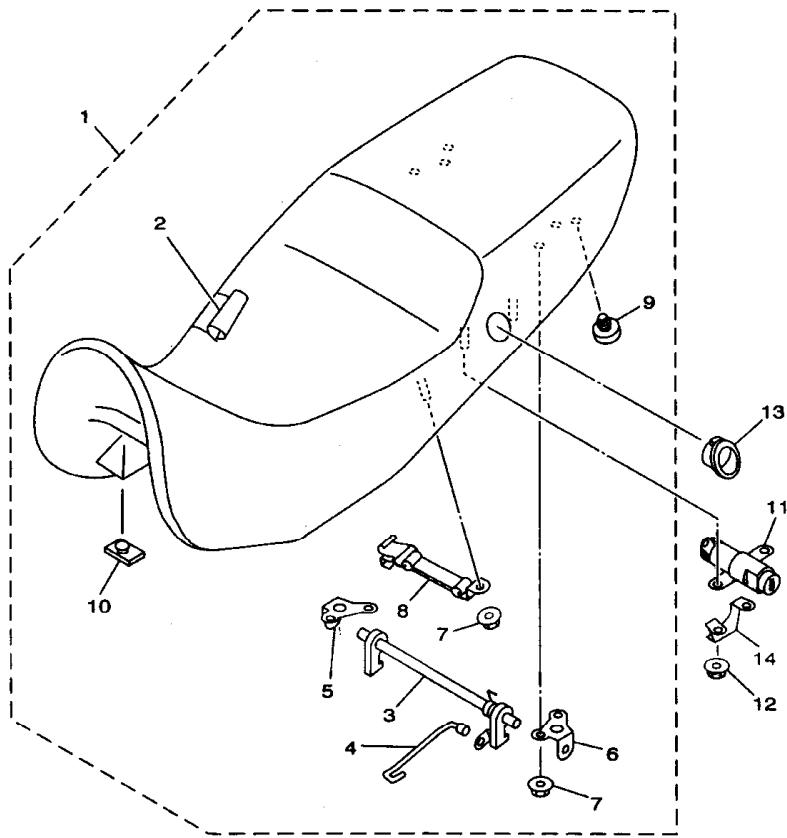

REF. NO.	PART NO.	DESCRIPTION			REMARKS
			4TX3	5AP2	
1	4TX-24730-01	DOUBLE SEAT ASSY	1	1	
2	4TX-24731-00	.COVER, SEAT	1	1	
3	4TX-24776-01	.LEVER, SEAT	1	1	
4	4TX-2478F-00	.ROD, CONNECTING	1	1	
5	4TX-24728-00	.BRACKET, SEAT	1	1	
6	4TX-24718-00	.BRACKET, SEAT	1	1	
7	90179-06635	.NUT	6	6	
8	4TX-21376-00	.BAND, TOOL	2	2	
9	22W-24741-00	.PAD, SEAT	2	2	
10	509-24724-00	.DAMPER, SEAT	2	2	
11	4BH-24705-00	SEAT LOCK ASSY	1	1	
12	95707-05500	NUT, FLANGE	2	2	
13	47X-24796-00	COVER	1	1	
14	4TX-24748-00	BRACKET, SEAT	1	1	

4TX1351-6270

FIG. 28 FRONT WHEEL

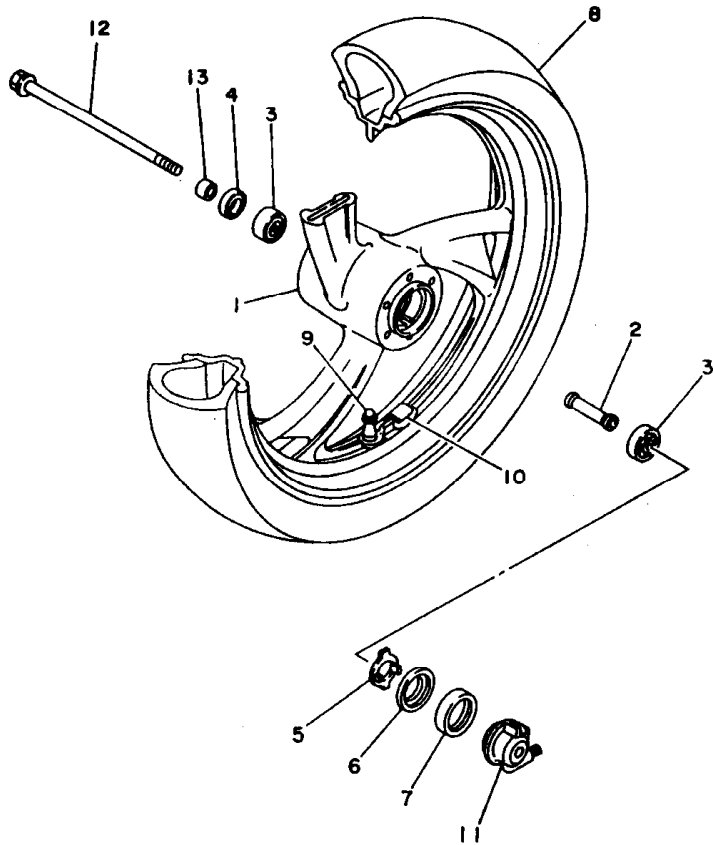

REF. NO.	PART NO.	DESCRIPTION	4TX3	5AR2	REMARKS
1	3VD-25168-00-7B	CAST WHEEL, FRONT	1	1	BIB2
2	90560-17233	SPACER	1	1	
3	93306-30319	BEARING	2	2	
4	93102-28022	OIL SEAL	1	1	
5	341-25149-00	CLUTCH, METER	1	1	
6	341-25846-00	RETAINER, CLUTCH	1	1	
7	93105-45017	OIL SEAL	1	1	
8	94111-1810C	TIRE (110/80ZR18 BATTLAX BT-54F) TIRE (110/80ZR18 MACADAM 90X)	1	1	UR BRIDGESTONE UR LM MICHELIN FOR ITALY
9	93900-00030	VALVE, RIM	1	1	
10	29L-25398-00	BALANCER, WHEEL (10G)	1	1	UR
	29L-25398-10	BALANCER, WHEEL (20G)	1	1	UR
	29L-25398-20	BALANCER, WHEEL (30G)	1	1	UR
11	4TX-25190-10	GEAR UNIT ASSY	1	1	
12	3GM-25181-03	AXLE, WHEEL	1	1	
13	90387-177R1	COLLAR	1	1	

4TX135I-6280

FIG. 29 FRONT BRAKE CALIPER

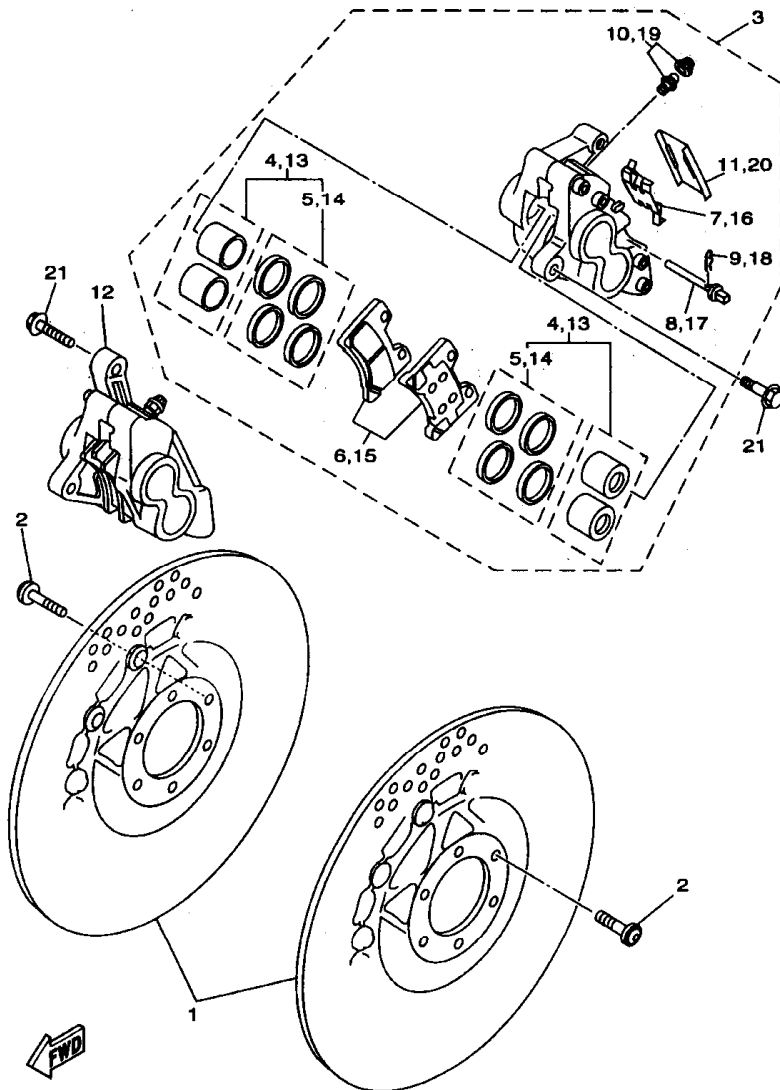

4TX1351-6290

REF. NO.	PART NO.	DESCRIPTION	4TX3	5AP2	REMARKS
1	4HM-2581T-01	DISC BRAKE ASSY	2	2	
2	90109-083G4	BOLT	12	12	
3	3HE-2580T-70	CALIPER ASSY (LEFT)	1	1	
4	3HE-W0057-50	PISTON ASSY, CALIPER	2	2	
5	3HE-W0047-50	CALIPER SEAL KIT	2	2	
6	3GM-W0045-03	BRAKE PAD KIT	1	1	
7	3GM-25919-00	SUPPORT, PAD	1	1	
8	3HE-25924-00	PIN, PAD	2	2	
9	3GM-25925-00	CLIP	2	2	
10	1J3-W0048-00	BLEED SCREW KIT	1	1	
11	1KT-25836-00	COVER, DUST	1	1	
12	3HE-2580U-70	CALIPER ASSY (RIGHT)	1	1	
13	3HE-W0057-50	PISTON ASSY, CALIPER	2	2	
14	3HE-W0047-50	CALIPER SEAL KIT	2	2	
15	3GM-W0045-03	BRAKE PAD KIT	1	1	
16	3GM-25919-00	SUPPORT, PAD	1	1	
17	3HE-25924-00	PIN, PAD	2	2	
18	3GM-25925-00	CLIP	2	2	
19	1J3-W0048-00	BLEED SCREW KIT	1	1	
20	1KT-25836-00	COVER, DUST	1	1	
21	90105-10638	BOLT, WASHER BASED	4	4	

FIG. 30 REAR WHEEL

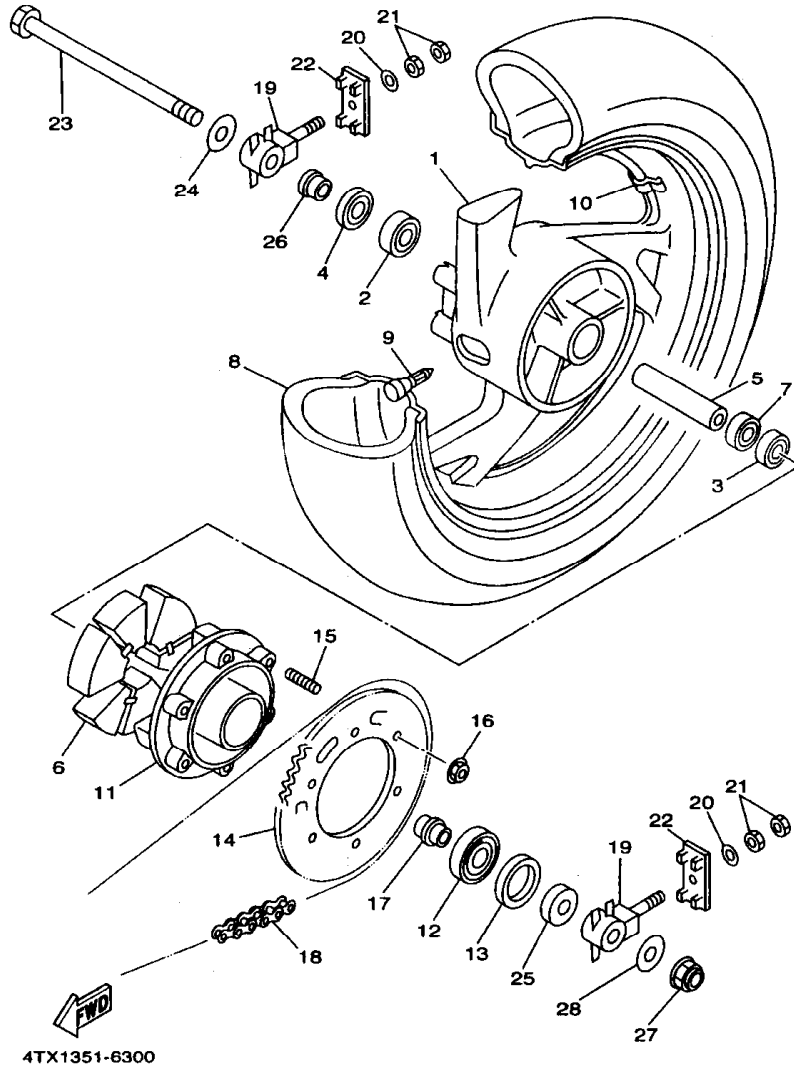

REF. NO.	PART NO.	DESCRIPTION	4TX3	5AR2	REMARKS
1	3VD-25338-00-7B	CAST WHEEL, REAR	1	1	BIB2
2	93306-30309	BEARING (B6303ZZ)	1	1	
3	93306-20314	BEARING (B6203)	1	1	
4	93102-25044	OIL SEAL	1	1	
5	90387-173M5	COLLAR	1	1	
6	4TX-25364-00	DAMPER	3	3	
7	93306-20314	BEARING (B6203)	1	1	
8	94115-1710D	TIRE (150/70ZR17 BATTLEAX BT-54R)	1	1	UR BRIDGESTONE
*		TIRE (150/70ZR17 MACADAM 90X)	1		UR LM MICHELIN FOR ITALY
9	93900-00030	VALVE, RIM	1	1	
10	29L-25398-00	BALANCER, WHEEL (10G)	1	1	UR
	29L-25398-10	BALANCER, WHEEL (20G)	1	1	UR
	29L-25398-20	BALANCER, WHEEL (30G)	1	1	UR
11	1AE-25366-00	CLUTCH, HUB	1	1	
12	93306-37207	BEARING	1	1	
13	93105-42024	OIL SEAL	1	1	
14	4TX-25442-00	SPROCKET, DRIVEN (42T)	1	1	
15	90116-10485	BOLT, STUD	6	6	
16	95607-10200	NUT, SELF-LOCKING	6	6	
17	90387-177K0	COLLAR	1	1	
18	94581-46114	CHAIN (D.I.D.525HV-114LE)	1	1	
19	3HE-25388-00	PULLER, CHAIN 1	2	2	
20	92907-08200	WASHER	2	2	
21	95307-08600	NUT	4	4	
22	3HE-22174-00	END 1	2	2	
23	3AJ-25381-01	AXLE, WHEEL	1	1	
24	90201-170T3	WASHER, PLATE	1	1	

FIG. 31 REAR BRAKE CALIPER

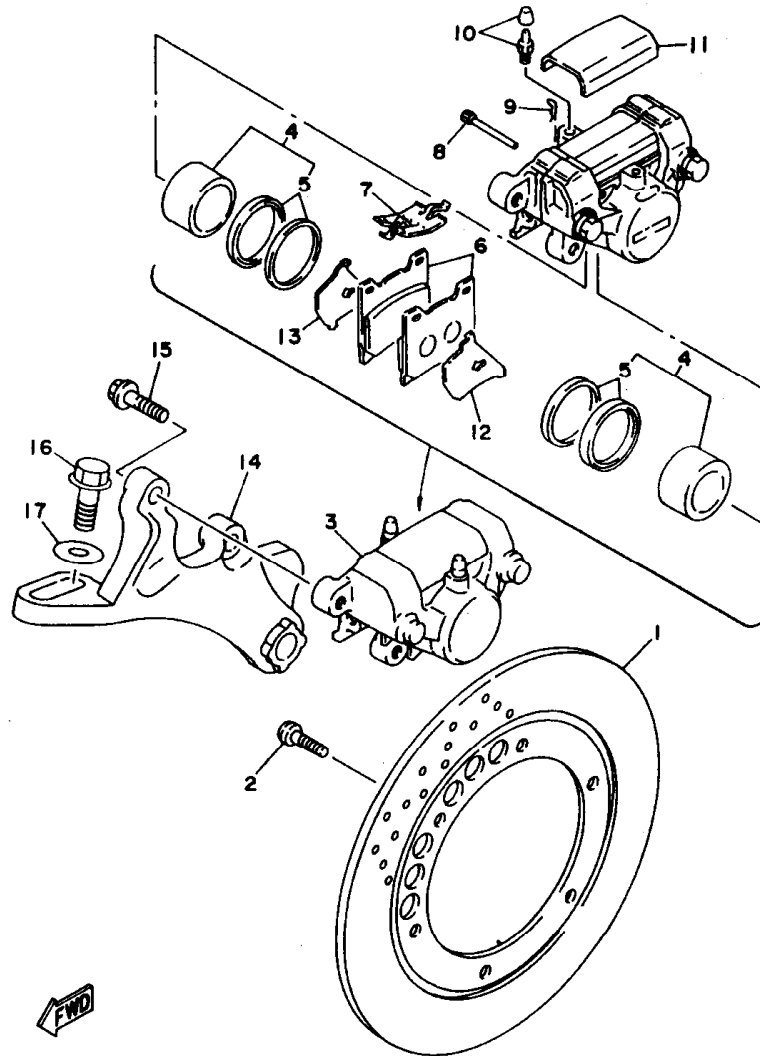

3VD1351-1310

REF. NO.	PART NO.	DESCRIPTION	4TX3	5AR2	REMARKS
1	4HM-2582W-00	DISC, REAR BRAKE 2	1	1	
2	90109-083G4	BOLT	6	6	
3	4TX-2580W-00	CALIPER ASSY, REAR 2	1	1	
4	31A-W0057-00	.PISTON ASSY, CALIPER	1	1	
5	31A-W0047-00	.CALIPER SEAL KIT	1	1	
6	4SV-W0045-50	.BRAKE PAD KIT	1	1	
7	29L-25919-00	.SUPPORT, PAD	1	1	
8	3HE-25924-00	.PIN, PAD	2	2	
9	3GM-25925-00	.CLIP	2	2	
10	1J3-W0048-00	.BLEED SCREW KIT	2	2	
11	42H-25836-00	.COVER, DUST	1	1	
12	1FK-25827-00	.SHIM, CALIPER	1	1	
13	1FK-25828-00	.SHIM, CALIPER	1	1	
14	3VD-25819-00	BRACKET, CALIPER	1	1	
15	90105-10638	BOLT, WASHER BASED	2	2	
16	95827-10030	BOLT, FLANGE	1	1	
17	90201-10437	WASHER, PLATE	1	1	

FIG. 32 STEERING HANDLE. CABLE

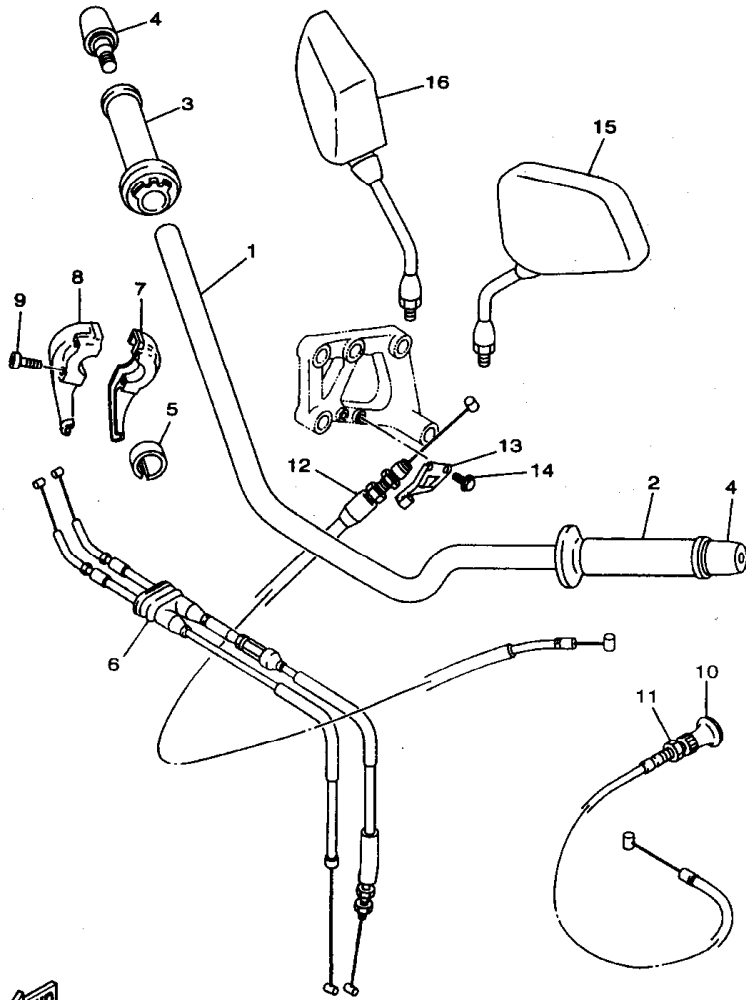

REF. NO.	PART NO.	DESCRIPTION	4TX3	5AR2	REMARKS
1	3VD-26111-11	HANDLEBAR	1	1	
2	1KG-26241-00	GRIP (LEFT)	1	1	
3	3FH-26240-00	GRIP ASSY	1	1	
4	51J-26246-01	END, GRIP	2	2	
5	90387-22660	COLLAR	1	1	
6	4TX-26302-00	THROTTLE CABLE ASSY	1	1	
7	3XW-26281-01	CAP, GRIP UPPER	1	1	
8	3XW-26282-01	CAP, GRIP LOWER	1	1	
9	98507-05035	SCREW, PAN HEAD	2	2	
10	4TX-26331-00	CABLE, STARTER 1	1	1	
11	1VJ-26333-00	NUT	1	1	
12	4TX-26335-00	CABLE, CLUTCH	1	1	
13	4TX-26292-00	STAY	1	1	
14	95027-06012	BOLT, FLANGE	2	2	
15	4TX-26280-00	REAR VIEW MIRROR ASSY(LEFT)	1	1	
16	3VD-26290-01	REAR VIEW MIRROR ASSY(RIGHT)	1	1	

4TX1351-6320

FIG. 33 FRONT MASTER CYLINDER

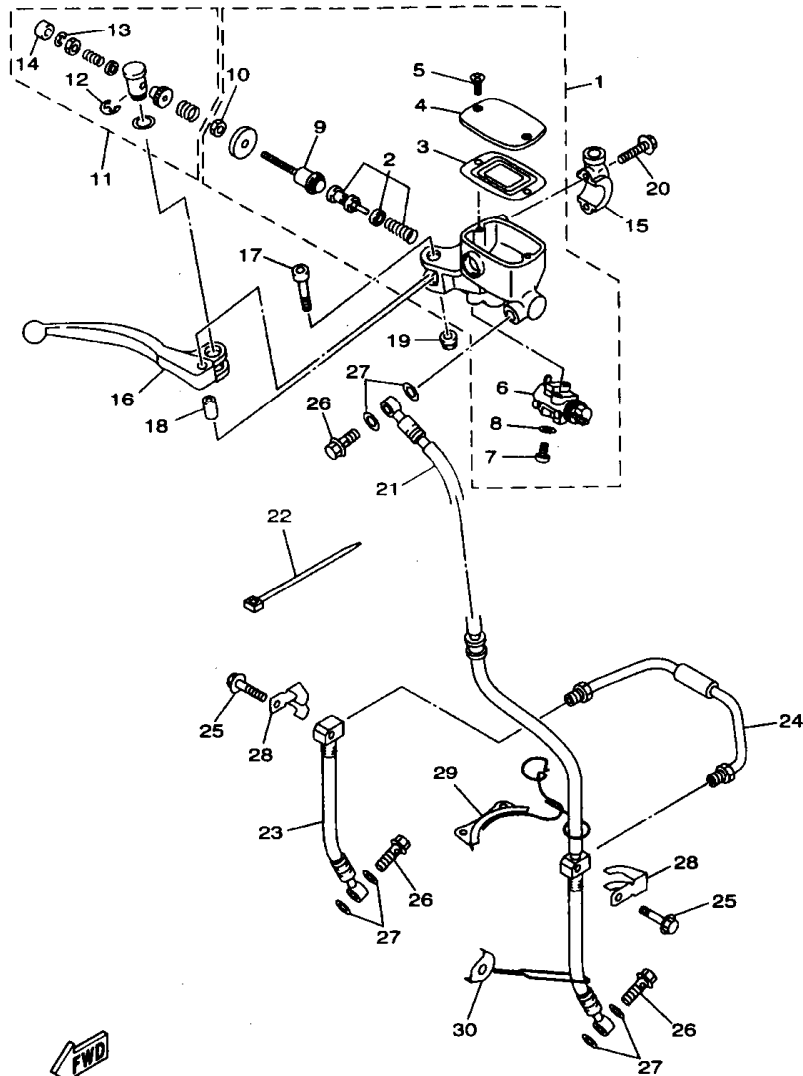

FWD
4TX1351-6331

REF. NO.	PART NO.	DESCRIPTION	4TX3	5AR2	REMARKS
1	4TX-W2587-00	MASTER CYLINDER SUB ASSY	1	1	
2	4BH-W0041-00	.CYLINDER KIT, MASTER	1	1	
3	3YX-25854-00	.DIAPHRAGM, RESERVOIR	1	1	
4	4TX-25852-00	.CAP, RESERVOIR	1	1	
5	98706-04012	.SCREW, FLAT HEAD	2	2	
6	4BH-83980-00	.FRONT STOP SWITCH ASSY	1	1	
7	98506-04014	.SCREW, PAN HEAD	2	2	
8	92906-04600	.WASHER, PLATE	2	2	
9	3YX-25880-00	.PUSH ROD COMP.	1	1	
10	95301-06600	.NUT	1	1	
11	3YX-W0091-02	SCREW KIT, MASTERCYLINDER	1	1	
12	3YX-25866-00	.CIRCLIP	1	1	
13	3YX-25866-10	.CIRCLIP	1	1	
14	3YX-2583H-00	.BOOT	1	1	
15	3YX-25867-00	BRACKET, MASTER CYLINDER	1	1	
16	3YX-83922-00	LEVER 2	1	1	
17	3YX-2589F-00	BOLT, LEVER	1	1	
18	3YX-25838-00	SLEEVE, CALIPER	1	1	
19	95606-06100	NUT, U	1	1	
20	95026-06030	BOLT, FLANGE	2	2	
21	4TX-25872-00	HOSE, BRAKE 1	1	1	
22	1UA-82591-00	BAND	2	2	
23	4TX-25874-00	HOSE, BRAKE	1	1	
24	4TX-25871-00	PIPE, BRAKE	1	1	
25	95024-06025	BOLT, FLANGE	2	2	
26	90401-10159	BOLT, UNION	3	3	
27	90201-10118	WASHER, PLATE	6	6	

FIG. 33 FRONT MASTER CYLINDER

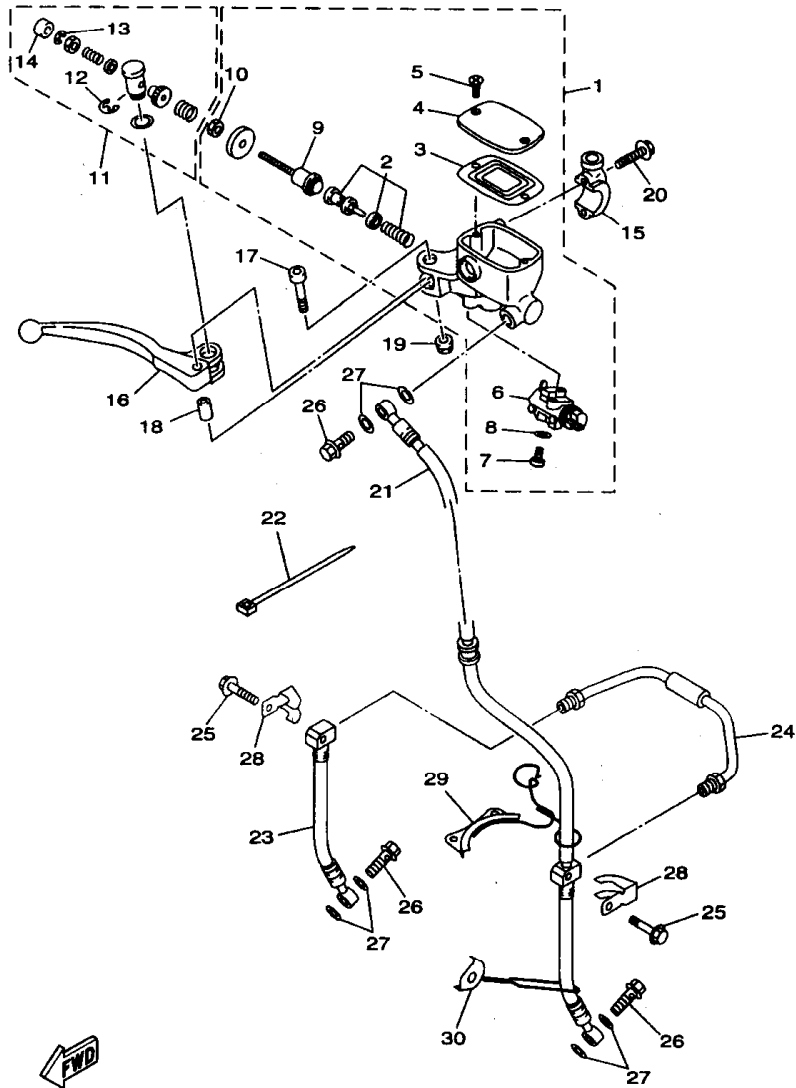

4TX1351-6331

REF. NO.	PART NO.	DESCRIPTION	4TX3	5AR2	REMARKS
28	4TX-25875-00	HOLDER, BRAKE HOSE 1	2	2	
29	4TX-26131-00	GUIDE, CABLE 1	1	1	
30	3VD-23317-00	HOLDER, CABLE	1	1	

FIG. 34 STAND. FOOTREST

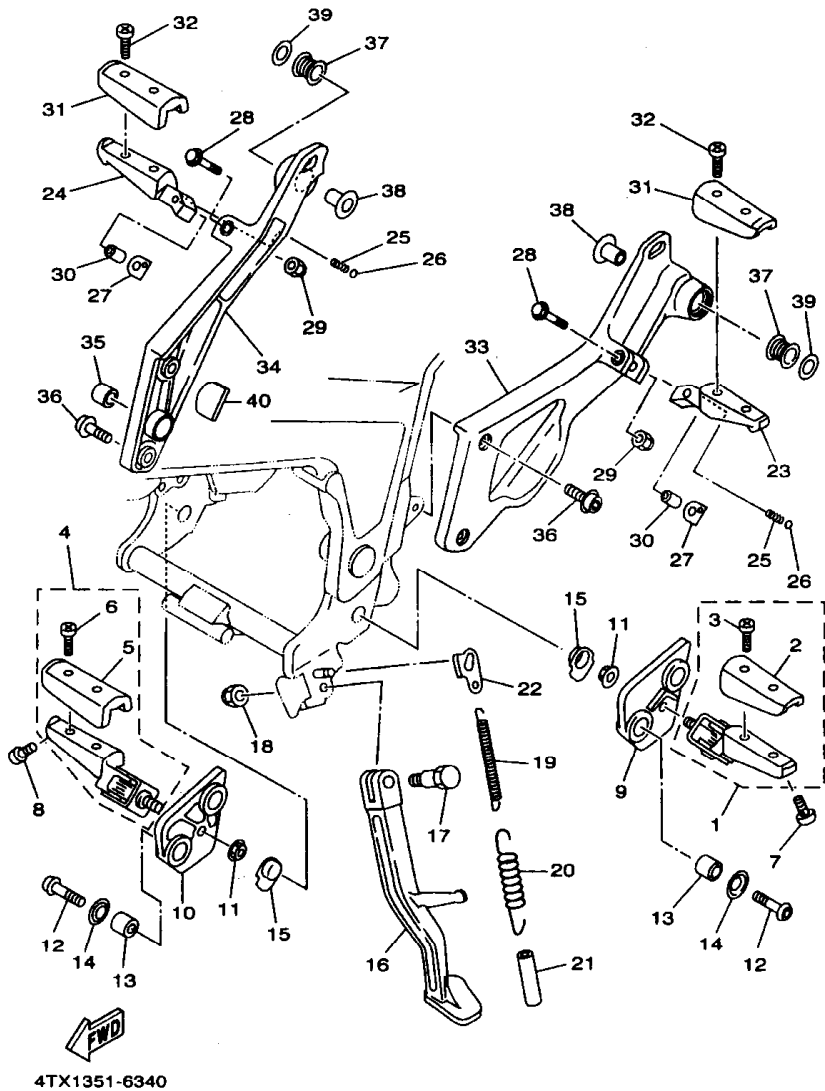

REF. NO.	PART NO.	DESCRIPTION	4TX3	5AR2	REMARKS
1	1UA-27410-00	FRONT FOOTREST ASSY (LEFT)	1	1	
2	46X-27413-00	.COVER, FOOTREST	1	1	
3	90157-05079	.SCREW, PAN HEAD	2	2	
4	1UA-27420-00	FRONT FOOTREST ASSY (RIGHT)	1	1	
5	46X-27413-00	.COVER, FOOTREST	1	1	
6	90157-05079	.SCREW, PAN HEAD	2	2	
7	90109-083E2	BOLT	1	1	
8	90109-083E2	BOLT	1	1	
9	3VD-27442-11	BRACKET 2	1	1	
10	3VD-27443-11	BRACKET 3	1	1	
11	90179-10247	NUT	2	2	
12	90110-08071	BOLT, HEXAGON SOCKET HEAD	4	4	
13	1NL-27424-00	DAMPER, FOOTREST 2	4	4	
14	90209-08295	WASHER	4	4	
15	3VD-27414-00	DAMPER, FOOTREST	2	2	
16	3VD-27311-01	STAND, SIDE	1	1	
17	90109-104E6	BOLT	1	1	
18	90185-10037	NUT, SELF-LOCKING	1	1	
19	90506-18224	SPRING, TENSION	1	1	
20	90506-26225	SPRING, TENSION	1	1	
21	1TX-27351-00	GUIDE, SIDE STAND	1	1	
22	3VD-27315-00	LINK, SIDE STAND	1	1	
23	4BR-27431-00	FOOTREST, REAR 1	1	1	
24	4BR-27441-00	FOOTREST, REAR 2	1	1	
25	90501-12743	SPRING, COMPRESSION	2	2	
26	93501-04011	BALL	2	2	
27	1HX-27437-00	WASHER, SPECIAL	4	4	

FIG. 34 STAND. FOOTREST

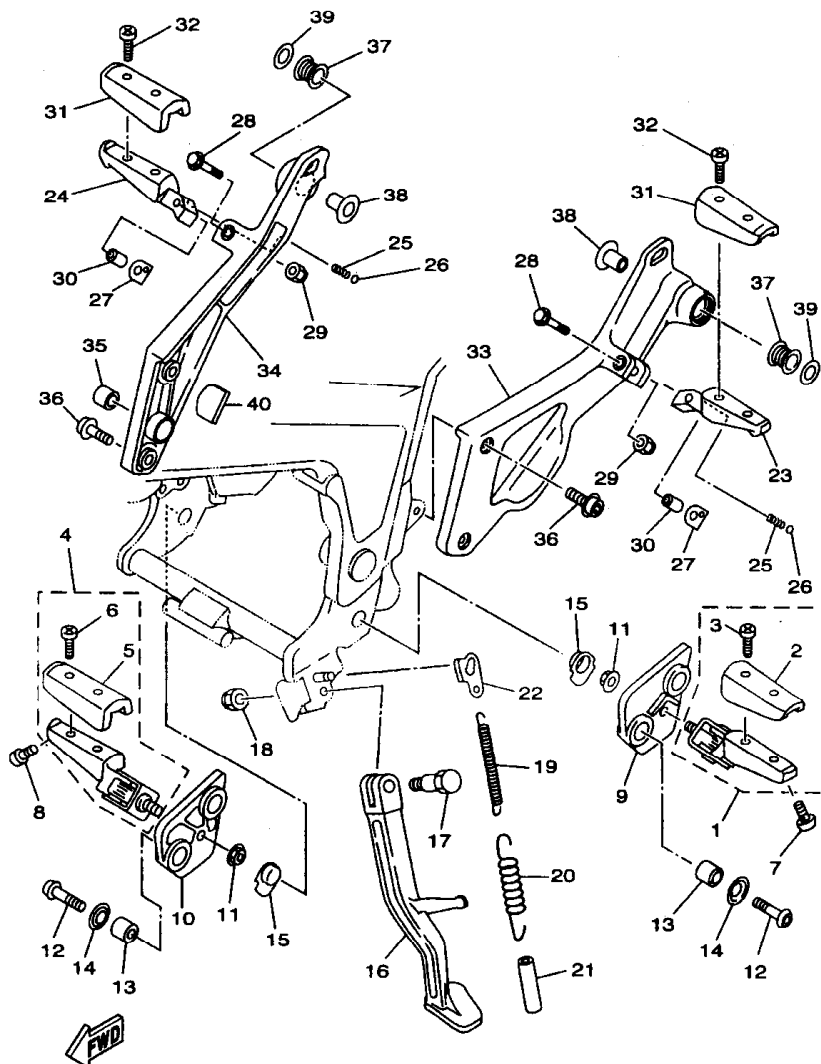

4TX1351-6340

REF. NO.	PART NO.	DESCRIPTION	4TX3	5AF2	REMARKS
28	95024-06045	BOLT, FLANGE	2	2	
29	95604-06200	NUT, U FLANGE	2	2	
30	90387-064H8	COLLAR	2	2	
31	2GH-27413-00	COVER, FOOTREST	2	2	
32	90157-05079	SCREW, PAN HEAD	4	4	
33	4TX-27412-00	BRACKET, FOOTREST 1	1	1	
34	4TX-27422-00	BRACKET, FOOTREST 2	1	1	
35	90380-20213	BUSH, SOLID	1	1	
36	90110-08199	BOLT, HEXAGON SOCKET HEAD	4	4	
37	36Y-27424-00	DAMPER, FOOTREST 2	2	2	
38	90387-104L8	COLLAR	2	2	
39	90201-10669	WASHER, PLATE	2	2	
40	3VD-2139X-00	DAMPER	1	1	

FIG. 35 REAR MASTER CYLINDER

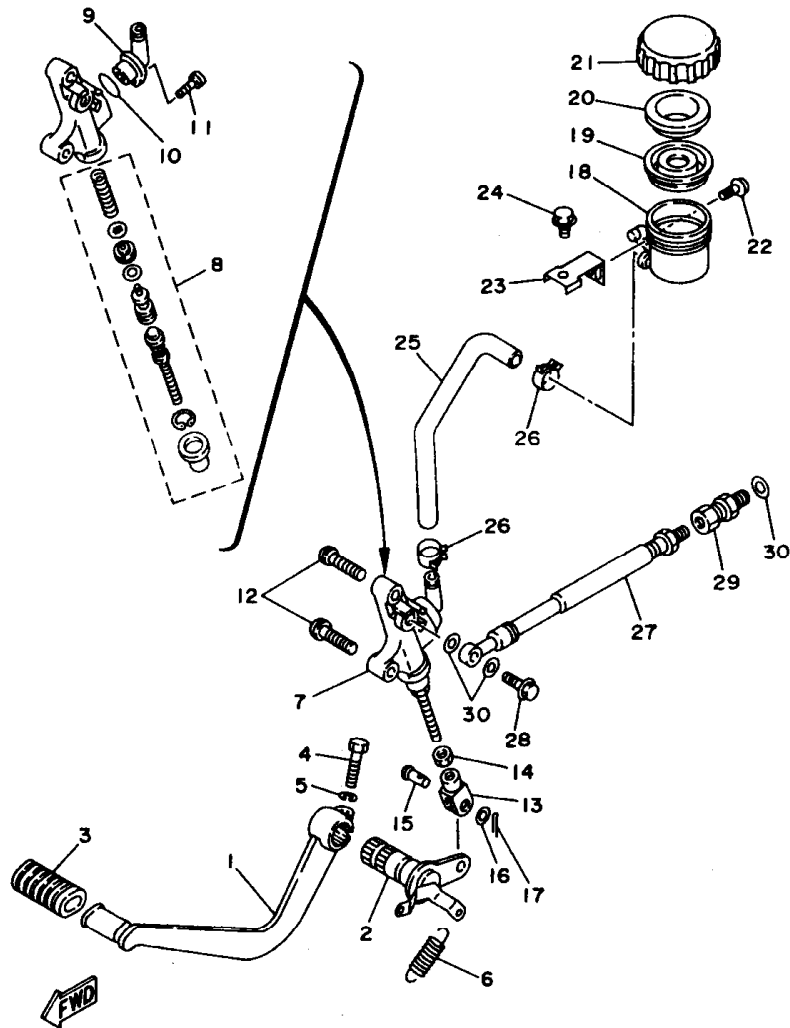

3VD9351-5350

REF. NO.	PART NO.	DESCRIPTION	4TX3	5AR2	REMARKS
1	3VD-27211-00	PEDAL, BRAKE	1	1	
2	3VD-27212-00	SHAFT, BRAKE PEDAL	1	1	
3	22N-18113-00	COVER, SHIFT PEDAL	1	1	
4	90101-06278	BOLT	1	1	
5	92907-06100	WASHER, SPRING	1	1	
6	90506-20192	SPRING, TENSION	1	1	
7	4TX-2583V-00	RR. MASTER CYLINDER ASSY.	1	1	
8	3VD-W0042-50	.CYLINDER KIT, MASTER	1	1	
9	3LN-2582A-00	.JOINT	1	1	
10	3LN-2585F-00	.O-RING	1	1	
11	3LN-2585H-00	.SCREW,SET	1	1	
12	92014-08020	BOLT, BUTTON HEAD	2	2	
13	47X-27222-00	JOINT	1	1	
14	95307-08700	NUT	1	1	
15	90240-08013	PIN, CLEVIS	1	1	
16	90201-08083	WASHER, PLATE	1	1	
17	91401-20012	PIN, COTTER	1	1	
18	47X-25894-00	TANK, RESERVOIR	1	1	
19	360-25854-01	DIAPHRAGM, RESERVOIR	1	1	
20	2GU-25855-00	BUSH,DIAPHRAGM	1	1	
21	2KF-25852-50	CAP, RESERVOIR	1	1	
22	90159-06056	SCREW, WITH WASHER	1	1	
23	3VD-2582E-02	HOLDER, RESERVE TANK	1	1	
24	95807-06010	BOLT, FLANGE	1	1	
25	3VD-25895-01	HOSE, RESERVOIR	1	1	
26	90467-14057	CLIP	2	2	
27	3VD-25872-51	HOSE, BRAKE 1	1	1	

FIG. 36 COWLING 1

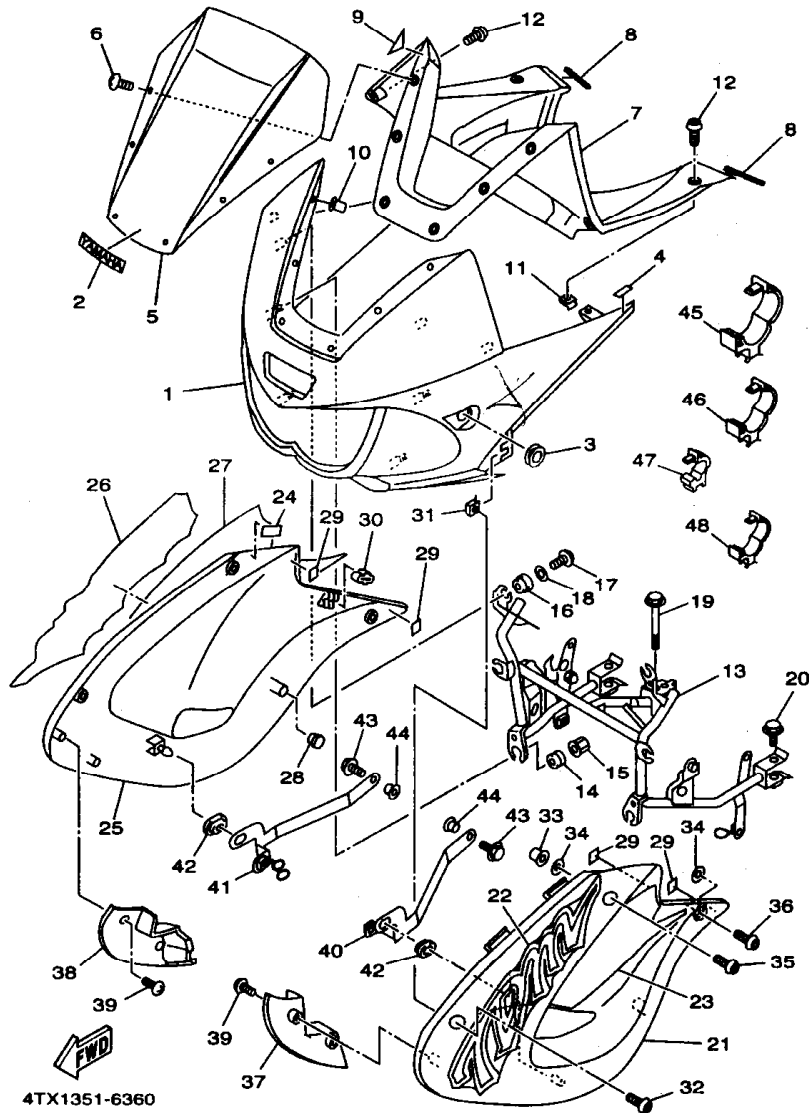

4TX1351-6360

REF. NO.	PART NO.	DESCRIPTION	4TX3	5AR2	REMARKS
1	4TX-2835G-00-0X	BODY, FRONT UPPER 1	1	1	UR BL2/LGB
	4TX-2835G-00-2X	BODY, FRONT UPPER 1	1	1	UR DRYC1/LGB
	4TX-2835G-00-4X	BODY, FRONT UPPER 1	1	1	UR DPBMC/LGB
2	99237-00080	EMBLEM, YAMAHA	1	1	UR FOR BL2, DRYC1
	99236-00080	EMBLEM, YAMAHA	1	1	UR FOR DPBMC
3	4KM-28371-00	DAMPER	2	2	
4	4TX-21717-00	DAMPER	4	4	
5	4TX-28381-00	WINDSHIELD	1	1	
6	90150-05024	SCREW, ROUND HEAD	6	6	
7	4TX-2836K-00	PANEL, INNER 1	1	1	
8	4TX-28345-00	MOLE 1	2	2	
9	4TX-21649-00	DAMPER	2	2	
10	90179-05523	NUT	6	6	
11	90183-05042	NUT, SPRING	2	2	
12	90167-05076	SCREW, TAPPING	4	4	
13	4TX-28356-00	STAY 1	1	1	
14	90480-14229	GROMMET	4	4	
15	90179-06500	NUT	4	4	
16	90480-13428	GROMMET	2	2	
17	97707-40010	SCREW, TAPPING	2	2	
18	90201-052E8	WASHER, PLATE	2	2	
19	95817-08080	BOLT, FLANGE	1	1	
20	95817-08035	BOLT, FLANGE	2	2	
21	4TX-2835U-00-95	PANEL 1	1	1	UR SLAS FOR BL2
	4TX-2835U-00-4B	PANEL 1	1	1	UR BL2 FOR DRYC1,DPBMC
22	4TX-28328-30	EMBLEM	1	1	UR FOR BL2
	5AR-28328-00	EMBLEM	1	1	UR FOR DRYC1

FIG. 36 COWLING 1

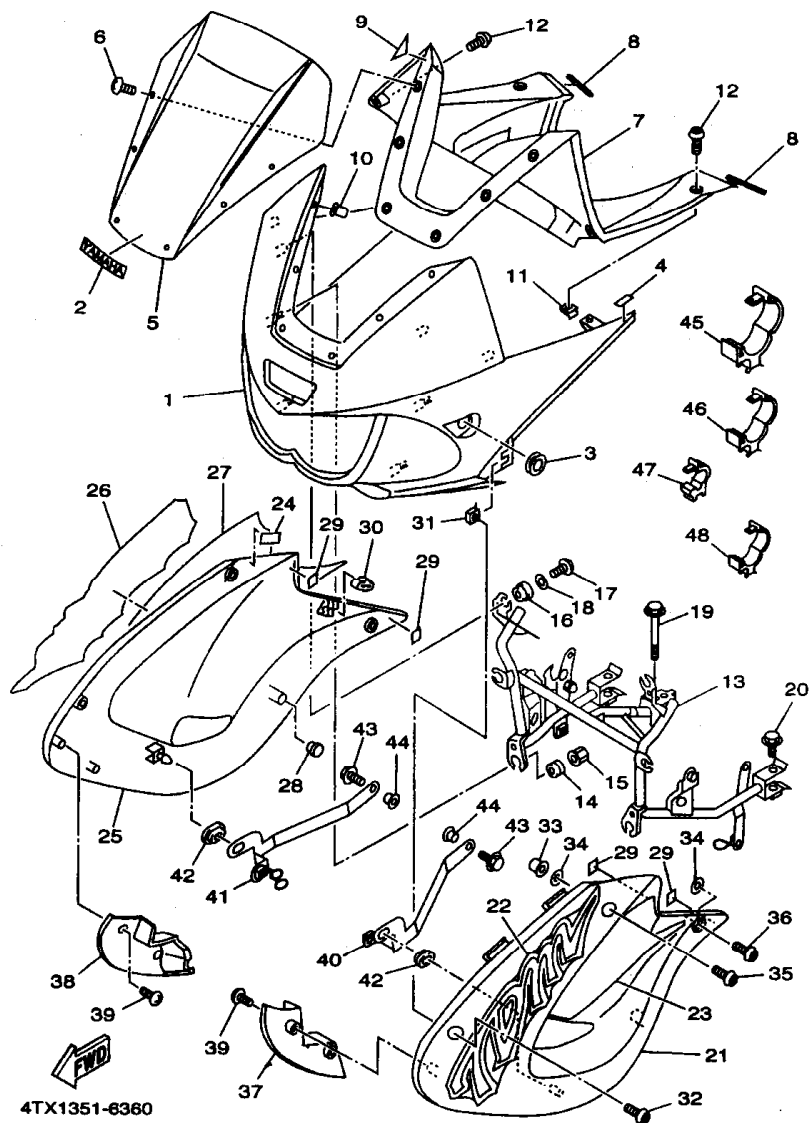

REF. NO.	PART NO.	DESCRIPTION	4TX3	5AR2	REMARKS
22	5AR-28328-20	EMBLEM	1	1	UR FOR DPBMC
23	4TX-28391-30	GRAPHIC 1	1	1	UR FOR BL2
	4TX-28391-40	GRAPHIC 1	1	1	UR FOR DRYC1
	4TX-28391-60	GRAPHIC 1	1	1	UR FOR DPBMC
24	30X-2139X-00	DAMPER	2	2	
25	4TX-2835V-00-95	PANEL 2	1	1	UR SLAS FOR BL2
	4TX-2835V-00-4B	PANEL 2	1	1	UR BL2 FOR DRYC1,DPBMC
26	4TX-28338-30	EMBLEM	1	1	UR FOR BL2
	5AR-28338-00	EMBLEM	1	1	UR FOR DRYC1
	5AR-28338-20	EMBLEM	1	1	UR FOR DPBMC
27	4TX-28392-30	GRAPHIC 2	1	1	UR FOR BL2
	4TX-28392-40	GRAPHIC 2	1	1	UR FOR DRYC1
	4TX-28392-60	GRAPHIC 2	1	1	UR FOR DPBMC
28	90338-10132	PLUG	2	2	
29	2TV-21639-00	DAMPER 2	4	4	
30	15A-21717-00	DAMPER	2	2	
31	90183-05024	NUT, SPRING	2	2	
32	90110-05201	BOLT, HEXAGON SOCKET HEAD	2	2	
33	90179-05523	NUT	2	2	
34	90202-05224	WASHER, PLATE	4	4	
35	90149-05299	SCREW	2	2	
36	90110-05201	BOLT, HEXAGON SOCKET HEAD	2	2	
37	4TX-2837N-00	GRILL, AIR INTAKE 1	1	1	
38	4TX-2837R-00	GRILL, AIR INTAKE 2	1	1	
39	97707-50012	SCREW, TAPPING	4	4	
40	4TX-28321-00	STAY 1	1	1	
41	4TX-28322-00	STAY 2	1	1	

FIG. 36 COWLING 1

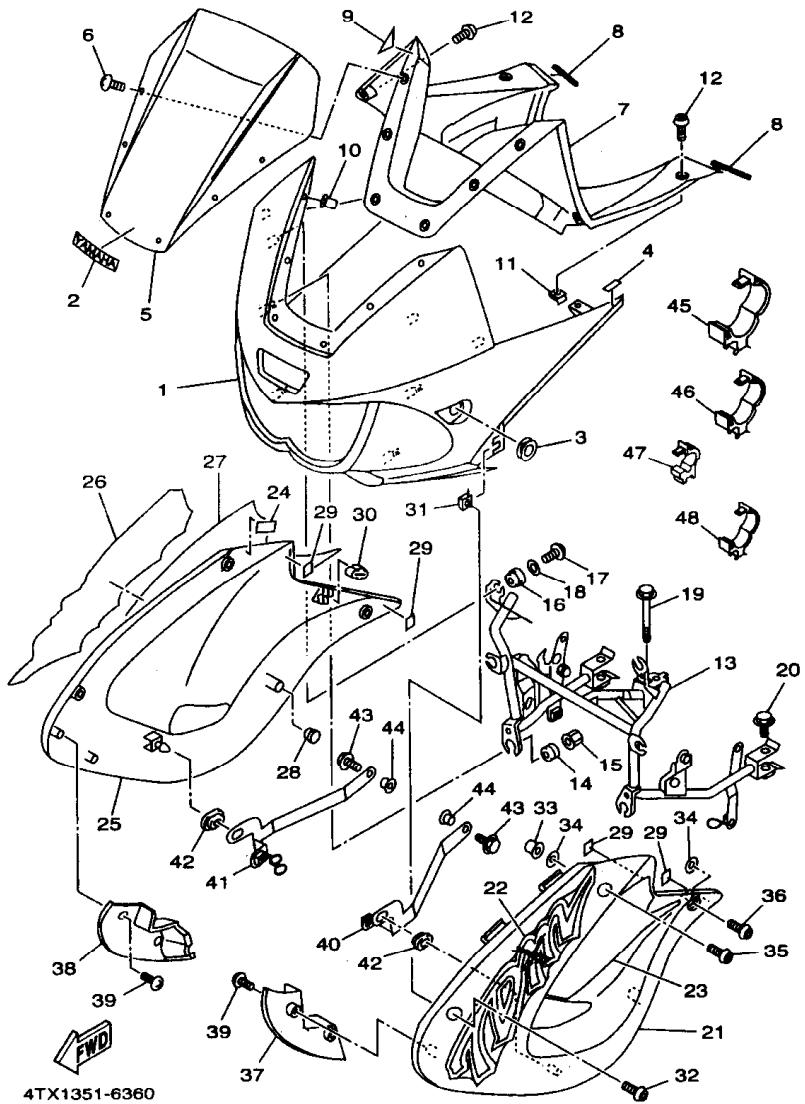

REF. NO.	PART NO.	DESCRIPTION	4TX3	5AF2	REMARKS
42	90480-01558	GROMMET	2	2	
43	95807-06012	BOLT, FLANGE	2	2	
44	90387-0910H	COLLAR	2	2	
45	90464-25217	CLAMP	1	1	
46	90464-20191	CLAMP	3	3	
47	90464-05188	CLAMP	1	1	
48	90464-15192	CLAMP	1	1	

FIG. 37 GENERATOR

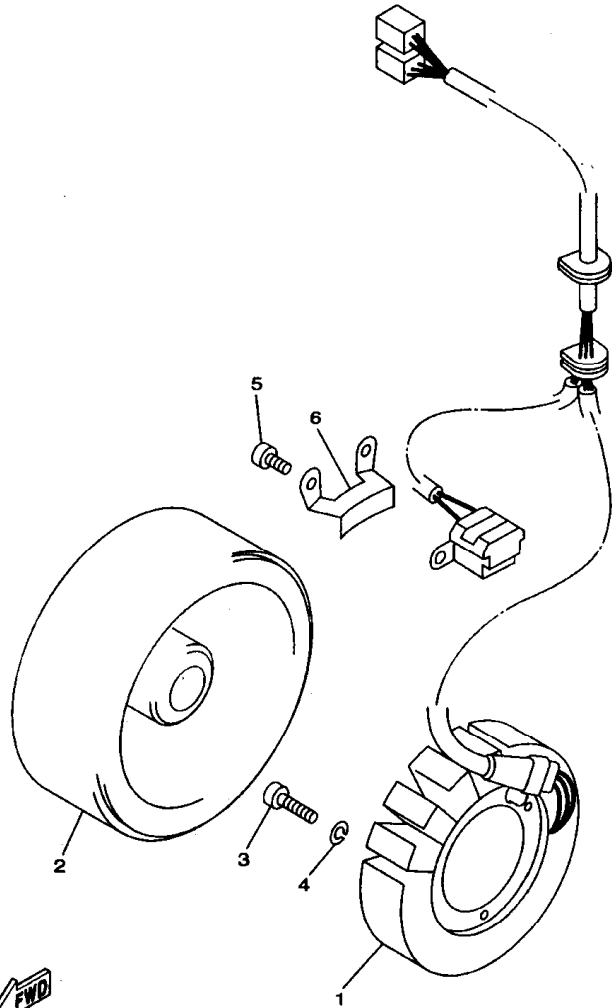

FWD
4TX1351-6370

REF. NO.	PART NO.	DESCRIPTION	4TX3	5AP2		REMARKS
1	4TX-81410-00	STATOR ASSY	1	1		
2	4TX-81450-00	ROTOR ASSY	1	1		
3	98507-08035	SCREW, PAN HEAD	3	3		
4	92907-06600	WASHER, PLATE	3	3		
5	91317-05016	BOLT	2	2		
6	90465-08380	CLAMP	1	1		

FIG. 38 FLASHER LIGHT

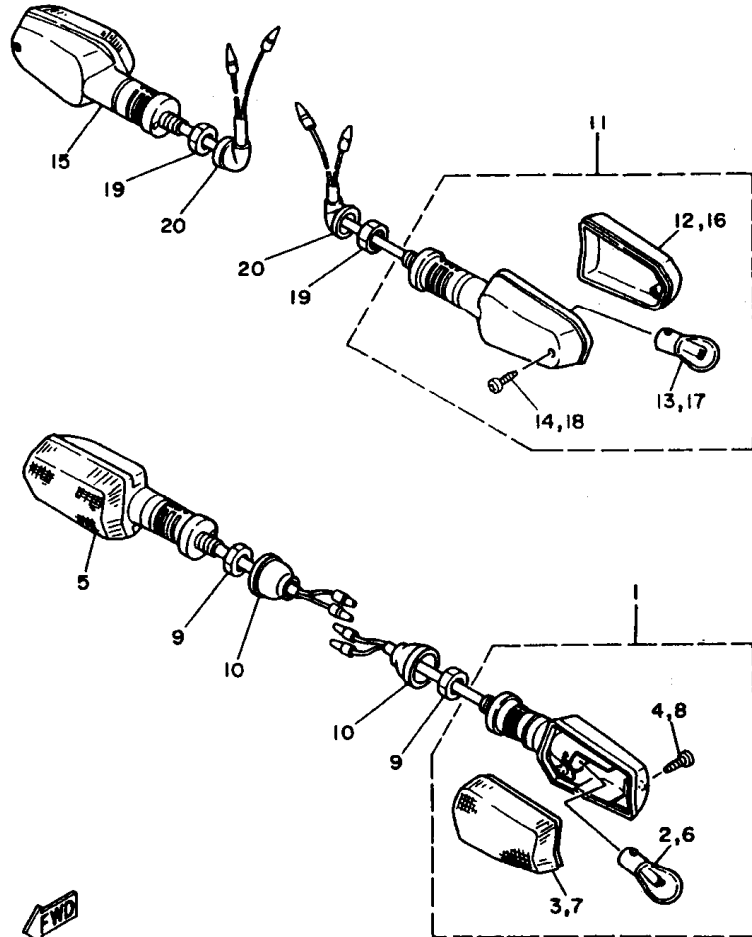

REF. NO.	PART NO.	DESCRIPTION	4TX3	5AR2	REMARKS
1	3GM-83310-00	FRONT FLASHER LIGHT ASSY 1	1	1	
2	306-83311-40	.BULB, FLASHER (12V-21W)	1	1	
3	51L-83332-01	.LENS, FLASHER	1	1	
4	97707-40620	.SCREW, TAPPING	1	1	
5	3GM-83320-00	FRONT FLASHER LIGHT ASSY 2	1	1	
6	306-83311-40	.BULB, FLASHER (12V-21W)	1	1	
7	51L-83342-01	.LENS, FLASHER 2	1	1	
8	97707-40620	.SCREW, TAPPING	1	1	
9	95307-12700	NUT	2	2	
10	10V-83365-00	CAP	2	2	
11	3VD-83330-00	REAR FLASHER LIGHT ASSY 1	1	1	
12	1VU-83332-00	.LENS, FLASHER	1	1	
13	306-83311-40	.BULB, FLASHER (12V-21W)	1	1	
14	97706-40620	.SCREW, TAPPING	1	1	
15	3VD-83340-00	FLASHER LIGHT ASSY 2	1	1	
16	1VU-83342-00	.LENS, FLASHER 2	1	1	
17	306-83311-40	.BULB, FLASHER (12V-21W)	1	1	
18	97706-40620	.SCREW, TAPPING	1	1	
19	95307-12600	NUT	2	2	
20	18G-83365-00	CAP	2	2	

 4TX1351-6380

FIG. 39 METER

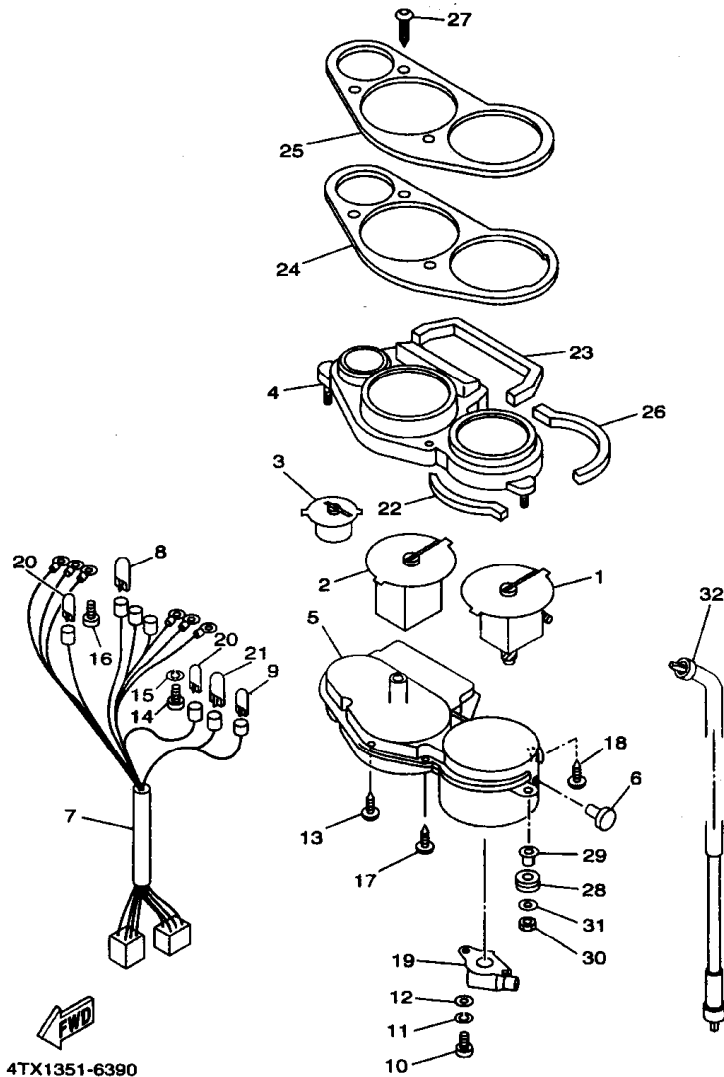

REF. NO.	PART NO.	DESCRIPTION	4TX3	5AP2	REMARKS
1	4TX-83570-00	SPEEDOMETER ASSY	1	1	UR
	4TX-83570-10	SPEEDOMETER ASSY	1		UR FOR GBR
2	4TX-83540-00	TACHOMETER ASSY	1	1	
3	4TX-83590-00	WATER TEMPERATURE ASSY	1	1	
4	4TX-83559-00	COVER, METER	1	1	
5	4TX-8353H-00	CASE, UNDER	1	1	
6	4TX-83578-00	KNOB, TRIP METER	1	1	
7	4TX-83509-00	SOCKET CORD ASSY	1	1	
8	4R0-83517-00	BULB (12V-3.4W T10)	3	3	
9	42X-83517-00	BULB (12V-3W)	1	1	
10	98507-04010	SCREW, PAN HEAD	4	4	
11	92907-04100	WASHER, SPRING	4	4	
12	92907-04600	WASHER	4	4	
13	90167-04057	SCREW, TAPPING	2	2	
14	98507-03010	SCREW, PAN HEAD	3	3	
15	92907-03100	WASHER	3	3	
16	90159-03102	SCREW, WITH WASHER	3	3	
17	90164-04008	SCREW, TAPPING	4	4	
18	90167-03058	SCREW, TAPPING	1	1	
19	4FM-83520-00	SOCKET CORD ASSY	1	1	
20	1YT-83517-00	BULB (12V-1.7W, T10)	2	2	
21	4G1-84744-00	BULB (12V-3.4W)	1	1	
22	4SV-83526-00	DAMPER 2	1	1	
23	4TX-83523-01	DAMPER	1	1	
24	4TX-83513-00	DAMPER	1	1	
25	4TX-83611-00	PANEL, METER	1	1	
26	4TX-8353B-00	DAMPER	2	2	

FIG. 39 METER

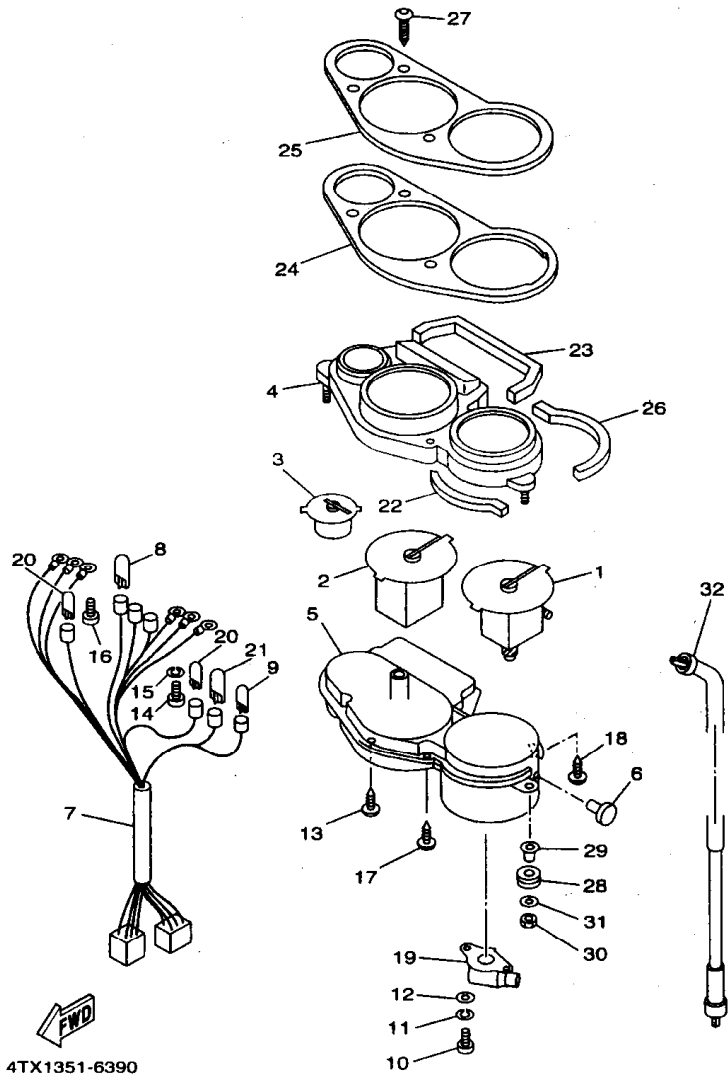

REF. NO.	PART NO.	DESCRIPTION	4TX3	5AR2	REMARKS
27	90167-05076	SCREW, TAPPING	3	3	
28	90480-14555	GROMMET	2	2	
29	90387-07391	COLLAR	2	2	
30	95307-06600	NUT	2	2	
31	90201-06380	WASHER, PLATE	2	2	
32	3XP-83550-01	SPEEDOMETER CABLE ASSY	1	1	



PARTS NEWS
INFORMAÇÃO DE MODIFICAÇÃO DE PEÇAS
INFORMACIÓN DE MODIFICACIÓN DE REPUESTOS

PT/PN. No. : 050.01/01

YAMAHA
GENUINE
 Parts & Accessories

PARTS CATALOG No. CATÁLOGO DE PEÇAS No. CATALOGO DE REPUESTOS No.	APPLICATION - MODEL : APLICAÇÃO - MODELO : APLICACIÓN - MODELO :
164TX-300E1 184TX-300E1 104TX-352S1 174TX-352S1 194XT-300E1	TDM850 1996/97/98/99/00~

RE. No. REF. No. REF. No.	OLD PART NUMBER CÓDIGO ANTIGO CÓDIGO ANTIGUO	NEW PART NUMBER CÓDIGO NOVO CODIGO NUEVO	PARTS DESCRIPTION DESCRIÇÃO DA PEÇA DESCRIPCIÓN DEL REPUESTO	SUPERSESSION SIMILAR SIMILAR
40-02	*	3GM-84314-40	BULB (12V - 55W - H3) LÂMPADA (12V - 55W - H3) BOMBILLA (12V - 55W - H3)	/
40-03	*	2LA-84314-G0	BULB (12V - 55W) LÂMPADA (12V - 55W) BOMBILLA (12V - 55W)	

DRAWING AND PARTS APPLICATION
 DESENHO E APLICAÇÃO DA PEÇA
 DISEÑO Y APLICACIÓN DE LO REPUESTO

PT/PN. No. : 050.01/01

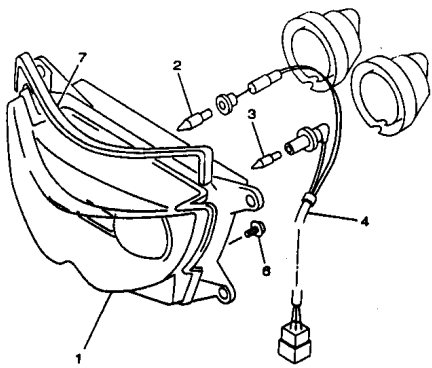

REF. No.	CÓDIGO	DISCRIMINAÇÃO	QT.	OBS.
01	4TX-84320-00	LENS ASSY	01	
02	3GM-84314-40	BULB (12V - 55W - H3)	01	LM HALOGEN
03	2LA-84314-G0	BULB (12V - 55W)	01	LM HALOGEN
04	3GM-84340-40	SOCKET CORD ASSY 1	01	
05	3GM-84397-40	COVER, SOCKET	02	
06	3TJ-84351-00	SCREW	01	

PARA CATÁLOGO EM INGLÊS / FOR PARTS CATALOGUE IN INGLSH (164TX-300E1 / 184TX-300E1 / 194TX-300E1)

01	4TX-84320-00	LENTE COMPLETO	01	
02	3GM-84314-40	AMPOLLETA (12V - 55W - H3)	01	LM HALOGEN
03	2LA-84314-G0	AMPOLLETA (12V - 55W)	01	LM HALOGEN
04	3GM-84340-40	ENCASTRE DE CABLE COMPLETO	01	
05	3GM-84397-40	CUBIERTA DE ENCASTRE	02	
06	3TJ-84351-00	TORNILLO	01	

PARA CATÁLOGO EM ESPANHOL / FOR PARTS CATALOGUE IN SPANISH (174TX-352S1 / 104TX-352S1)

*** P/C CORRECTION.**
 Please include this information in your parts catalogue.

*** CORREÇÃO DO CATÁLOGO DE PEÇAS.**
 Favor anexar esta correção em seu catálogo.

*** CORRECIÓN DE CATALOGO DE REPUESTOS.**
 Favor de anexar esta corrección en su catalogo.

YAMAHA MOTOR DO BRASIL LTDA.

DATE. : 17/01/01

FIG. 40 HEADLIGHT

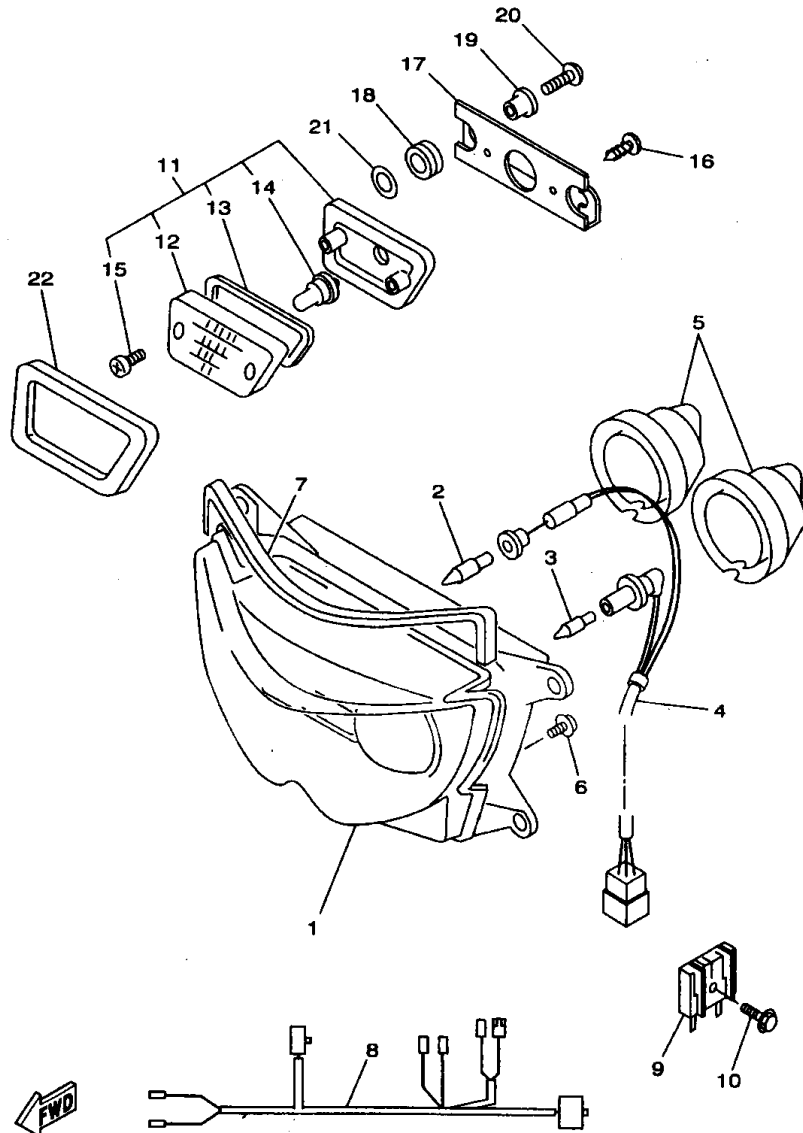

4TX1351-6400

REF. NO.	PART NO.	DESCRIPTION	4TX3	5AP2	REMARKS
1	4TX-84320-00	LENS ASSY	1	1	UR
	4TX-84320-10	LENS ASSY	1		UR FOR GBR
2	3GM-84314-40	BULB (12V-55W-H3)	1	1	LM HALOGEN
3	2LA-84314-G0	BULB (12V-55W)	1	1	LM HALOGEN
4	3GM-84340-40	SOCKET CORD ASSY 1	1	1	
5	3GM-84397-40	COVER, SOCKET	2	2	
6	3TJ-84351-00	SCREW	1	1	
7	4TX-84163-00	DAMPER	1	1	
8	4TX-84359-00	CORD, HEADLIGHT	1	1	
9	1Y8-81970-60	RECTIFIER ASSY	1	1	
10	95807-08020	BOLT, FLANGE	1	1	
11	3GM-84301-00	PILOT LIGHT ASSY 1	1	1	
12	3GM-84321-00	.LENS ASSY	1	1	
13	3GM-84322-00	.GASKET, LENS	1	1	
14	47G-85353-00	.BULB (12V-5W)	1	1	
15	3GM-84192-10	.SCREW, SPECIAL	2	2	
16	90167-05025	SCREW, TAPPING	2	2	
17	4TX-8431R-00	STAY, SETTING	1	1	
18	90480-10517	GROMMET	2	2	
19	90387-052U5	COLLAR	2	2	
20	90167-05037	SCREW, TAPPING	2	2	
21	90201-054K4	WASHER, PLATE	2	2	
22	3GM-84367-50	DAMPER, HEADLIGHT 2	1	1	

FIG. 41 TAILLIGHT

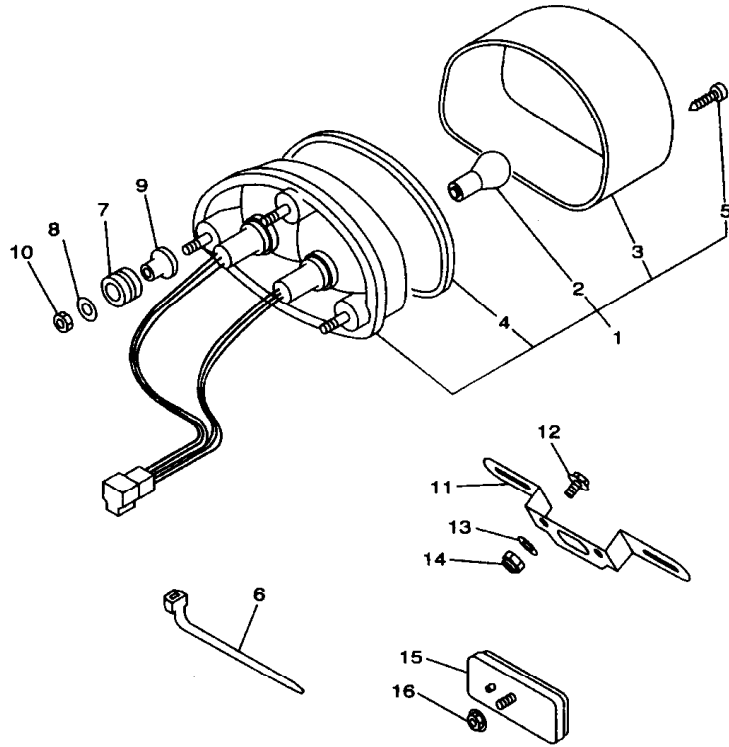

REF. NO.	PART NO.	DESCRIPTION	4TX3	5AR2	REMARKS
1	4TX-84710-00	TAILLIGHT UNIT ASSY	1	1	
2	31L-84714-00	.BULB, TAILLIGHT (12V-21/5W)	2	2	
3	4TX-84733-00	.LENS, TAILLIGHT	1	1	
4	4TX-84723-00	.GASKET, TAIL LENS	1	1	
5	97706-40620	.SCREW, TAPPING	2	2	
6	90464-13077	CLAMP	1	1	
7	90480-18276	GROMMET	3	3	
8	90201-06071	WASHER, PLATE	3	3	
9	90387-077M3	COLLAR	3	3	
10	95307-06600	NUT	3	3	
11	4TX-84751-00	BRACKET, LICENSE	1	1	
12	95027-06014	BOLT, FLANGE	2	2	
13	90201-06057	WASHER, PLATE	2	2	
14	95607-06100	NUT, U	2	2	
15	3Y6-85130-02	REAR REFLECTOR ASSY	1		UR
	3G1-85130-01	REAR REFLECTOR ASSY	1		UR FOR DNK,FIN, NOR,SWE
	4KM-85130-00	REAR REFLECTOR ASSY		1	
16	95707-05500	NUT, FLANGE	1	1	



4TX1351-6410

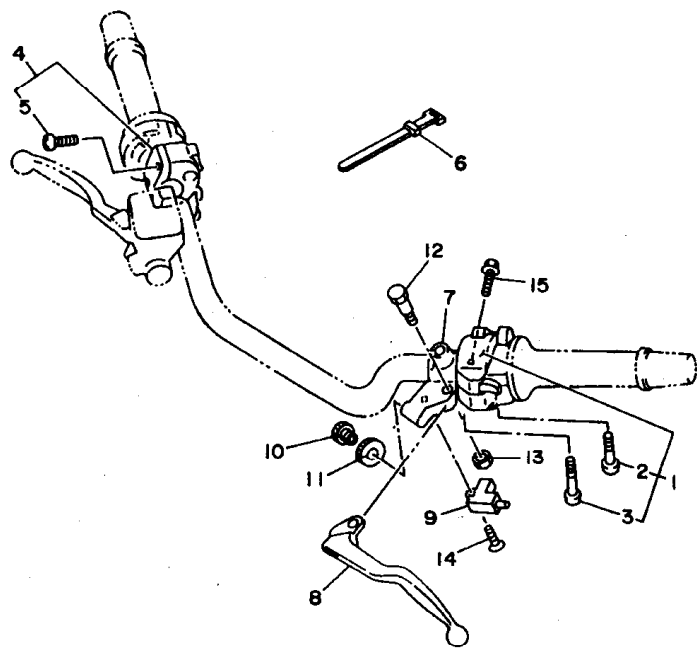

FIG. 42 HANDLE SWITCH. LEVER

REF. NO.	PART NO.	DESCRIPTION	4TX3	5A/R2	REMARKS
1	4TX-83969-00	SWITCH, HANDLE 5	1	1	
2	98507-05030	.SCREW, PAN HEAD	1	1	
3	98507-05040	.SCREW, PAN HEAD	1	1	
4	4TX-83975-00	SWITCH, HANDLE 2	1	1	
5	98507-05022	.SCREW, PAN HEAD	2	2	
6	437-83936-01	BAND, SWITCH CORD	2	2	
7	3YX-82911-00	HOLDER, LEVER 1	1	1	
8	3YX-83912-00	LEVER 1	1	1	
9	3YX-82917-00	SWITCH	1	1	
10	90123-08096	BOLT	1	1	
11	90179-08148	NUT	1	1	
12	3YX-83945-00	BOLT, LEVER	1	1	
13	95607-06100	NUT, U	1	1	
14	98707-03020	SCREW, FLAT HEAD	1	1	
15	95027-06020	BOLT, FLANGE	1	1	



4TX1351-6420

FIG. 43 ELECTRICAL 1

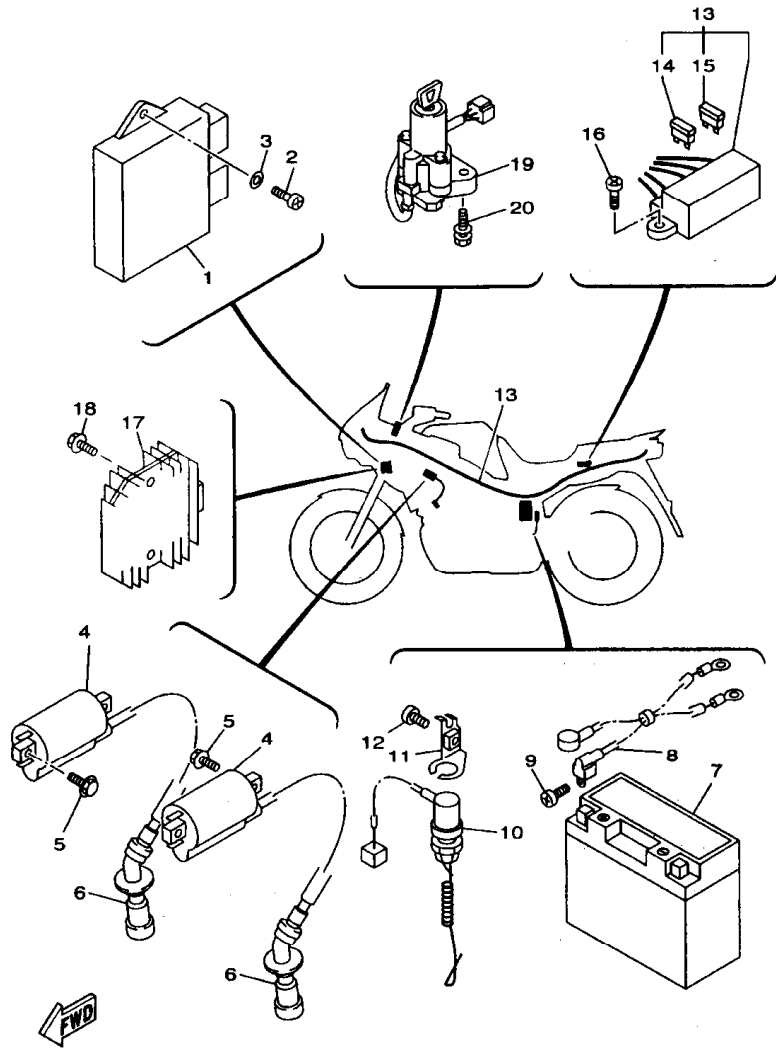

4TX1351-6430

REF. NO.	PART NO.	DESCRIPTION	4TX3	5AR2	REMARKS
1	4TX-82305-00	IGNITOR UNIT ASSY	1	1	
2	98507-06016	SCREW, PAN HEAD	2	2	
3	92907-06600	WASHER, PLATE	2	2	
4	3TB-82310-00	IGNITION COIL ASSY	2	2	
5	91317-05016	BOLT	4	4	
6	3LD-82370-00	PLUG CAP ASSY	2	2	
7	4TX-82100-01	BATTERY ASSY	1	1	
8	4TX-82509-00	WIRE, SUB LEAD	1	1	
9	98507-06008	SCREW, PAN HEAD	1	1	
10	4TX-82530-00	STOP SWITCH ASSY	1	1	
11	4TX-82539-00	STAY, STOP SWITCH	1	1	
12	92014-06010	BOLT, BUTTON HEAD	1	1	
13	4TX-82590-20	WIRE HARNESS ASSY	1	1	
14	36Y-82151-00	.FUSE (15A-BL)	4	4	
15	2KW-82151-00	.FUSE (7.5A-BL)	3	3	
16	98907-06012	SCREW, BIND	2	2	
17	4JH-81960-01	RECTIFIER & REGULATOR ASSY	1	1	
18	95807-06020	BOLT, FLANGE	2	2	
19	4JH-82501-03	MAIN SWITCH STEERING LOCK	1	1	
20	90109-080G5	BOLT	2	2	

FIG. 44 ELECTRICAL 2

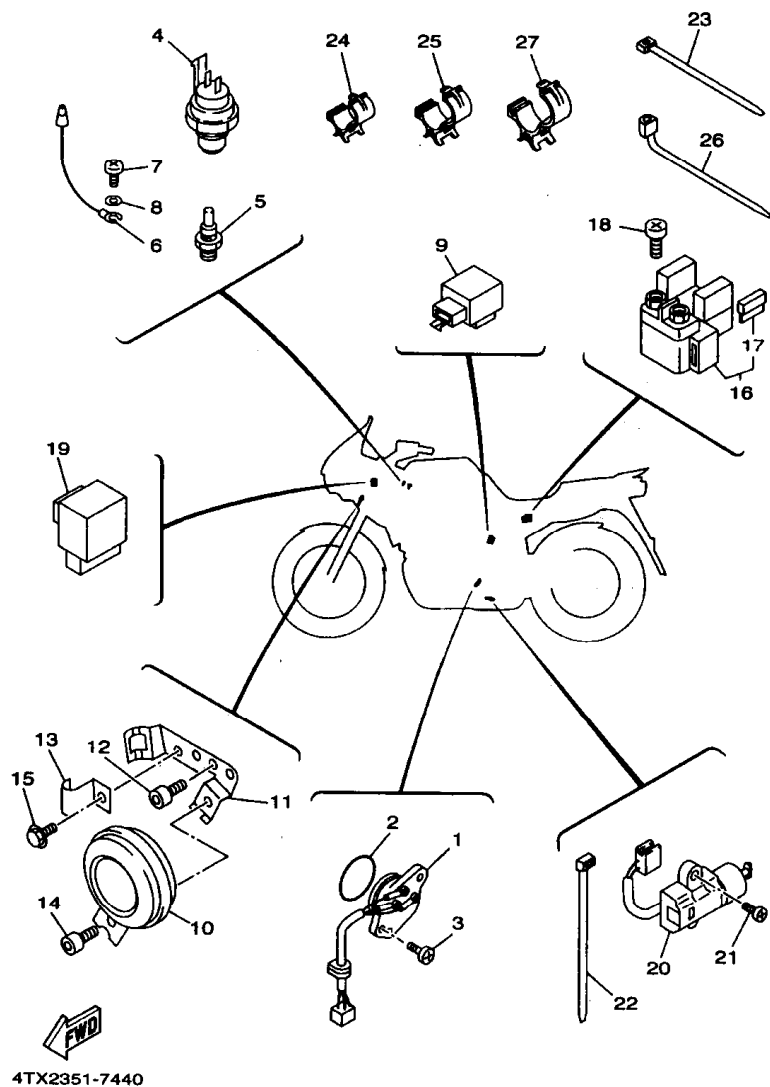

REF. NO.	PART NO.	DESCRIPTION	4TX3	5AR2	REMARKS
1	4TX-82540-00	NEUTRAL SWITCH ASSY	1	1	
2	93210-29196	O-RING	1	1	
3	98507-06016	SCREW, PAN HEAD	2	2	
4	3LN-82560-01	THERMO SWITCH ASSY	1	1	
5	11H-83591-00	THERMO UNIT	1	1	
6	4NX-83354-00	WIRE, EARTH LEAD 1	1	1	
7	98507-04008	SCREW, PAN HEAD	1	1	
8	92907-04600	WASHER	1	1	
9	3GM-83350-01	FLASHER RELAY ASSY	1	1	
10	4KM-83371-00	HORN	1	1	
11	4TX-23377-00	BRACKET, HORN	1	1	
12	91317-06014	BOLT	2	2	
13	4TX-23378-00	BRACKET, HORN	1	1	
14	91317-06010	BOLT	1	1	
15	95807-06010	BOLT, FLANGE	1	1	
16	4DN-81940-00	STARTER RELAY ASSY	1	1	
17	1AE-82151-00	.FUSE (30A-BL)	2	2	
18	98507-06008	SCREW, PAN HEAD	2	2	
19	4EP-81950-00	RELAY ASSY	1	1	
20	3LD-82566-50	SWITCH, SIDE STAND	1	1	
21	90157-05079	SCREW, PAN HEAD	2	2	
22	25G-83936-01	BAND, SWITCH CORD	2	2	
23	90464-25217	CLAMP	10	10	
24	90464-10190	CLAMP	7	7	
25	90464-15192	CLAMP	5	5	
26	90464-13073	CLAMP	2	2	
27	90464-20191	CLAMP	1	1	

INDEX

NUMERICAL INDEX

PARTNO.	GRID NO.	PARTNO.	GRID NO.	PARTNO.	GRID NO.	PARTNO.	GRID NO.	PARTNO.	GRID NO.	PARTNO.	GRID NO.
4BH-W0041-00	E - 12	3LD-11633-00	B - 4	4NX-12181-00	B - 8	3LD-13371-00	B - 12	3EN-14261-00	C - 5	4G0-15138-00	C - 8
3VD-W0042-50	F - 2	4NX-11636-00	B - 4	3LD-12210-00	B - 8	3VD-13411-00	B - 12	4TX-14294-00	E - 3	4H7-15138-00	B - 13
3GM-W0045-03	E - 7	4NX-11638-00	B - 4	3VD-12213-00	B - 8	3VD-13412-00	B - 12	3VD-14411-00	C - 2	3LD-15163-10	C - 15
4SV-W0045-50	E - 10	3VD-11650-00	B - 4	3YL-12232-00	D - 5	3VD-13414-00	B - 13	3VD-1442G-00	C - 2	3LD-15191-00	C - 9
3HE-W0047-50	E - 7	3LD-11654-00	B - 4	3LD-12241-00	B - 8	3VD-13415-00	B - 12	3VD-14421-00	C - 2	3VD-15199-00	C - 8
31A-W0047-00	E - 10	3LD-11656-00	B - 4	3LD-12247-00	B - 8	3VD-13416-00	B - 14	3VD-14422-00	C - 2	3VD-15316-00	C - 8
1J3-W0048-00	E - 7	3LD-11656-10	B - 4	3LD-12251-00	B - 8	4TX-13416-00	B - 14	3VD-14425-00	C - 2	3VD-15317-00	C - 8
	E - 10	3LD-11656-20	B - 4	3LD-12252-00	B - 8	3VD-13417-10	B - 13	3VD-14426-00	C - 2	3VD-15326-00	C - 10
	E - 7	3LD-11656-30	B - 4	4TX-12405-00	B - 10	4NX-13418-00	B - 14	1AE-14451-00	C - 2	3VD-15335-00	C - 10
3HE-W0057-50	E - 7	3LD-12111-01	B - 6	1AE-12410-00	B - 11	4X7-13440-01	B - 12	1AE-14452-00	C - 2	3F9-15362-00	B - 14
31A-W0057-00	E - 10	3LD-12112-01	B - 6	4NX-12413-00	B - 11	3VD-13447-00	B - 12	4BR-14452-00	C - 2	3VD-15411-11	C - 10
3YX-W0091-02	E - 12	3LD-12113-00	B - 6	4NX-12417-00	B - 11	4UN-13464-01	B - 13	4TX-14453-00	C - 2	3LD-15414-00	D - 2
3VD-W2165-00	D - 11	1WG-12116-00	B - 6	4TX-1243A-00	C - 6	4TX-13465-00	B - 14	1HX-14565-00	C - 4	3VD-15416-10	C - 9
4TX-W2587-00	E - 12	3LD-12117-00	B - 6	4NX-1243E-00	C - 6	4TX-13467-00	B - 14	1UY-14565-00	C - 4	3VD-15417-01	C - 10
4NX-Y1119-10	B - 2	3LD-12118-00	B - 6	4NX-1243F-00	C - 6	11H-13490-00	B - 13	812-14594-00	C - 5	3LD-15418-00	C - 10
4UN-Y1242-00	B - 9	3LD-12119-00	B - 6	1AA-12435-00	B - 10	3LD-13586-01	C - 2	4TX-14602-00	C - 7	3VD-15420-01	C - 10
3VD-Y2151-10-P8	D - 6	3LD-12121-00	B - 6	1UF-12435-00	B - 10	3LD-13597-01	C - 2	3VD-14613-00	C - 7	4UN-15425-00	C - 10
3VD-Y2151-10-P8	D - 6	1WG-12153-09	B - 6	1KT-12437-00	B - 10	4NX-13910-00	E - 3	4TX-14710-00	C - 7	4UN-15426-00	C - 11
3VD-Y2151-10-4B	D - 6	1WG-12153-11	B - 6	3LD-12439-00	B - 9	4TX-13938-00	E - 3	3VD-14755-00	C - 7	4UN-15430-00	C - 10
3VD-Y2161-G0	D - 6	1WG-12153-21	B - 6	4TX-1244E-00	B - 11	3EN-1410A-00	C - 5	3LD-1490H-00	C - 5	3LD-15449-00	C - 10
3VD-Y2161-01	D - 6	1WG-12153-31	B - 6	3VD-12459-00	B - 9	4TX-14103-00	C - 6	5AR-1490H-00	C - 5	3VD-15451-00	C - 10
3VD-11101-20	B - 2	3LD-12168-A0	B - 6	4TX-12461-00	B - 10	12R-14105-00	C - 5	4NX-1490J-00	C - 5	3VD-15456-00	C - 9
2GH-1111G-00	B - 2	3LD-12168-F0	B - 6	4FL-12462-00	B - 10	4CC-14105-00	C - 5	3EN-1490K-00	C - 6	4NX-15461-00	C - 11
3LD-11133-10	B - 2	3LD-12168-H1	B - 6	3VD-12465-00	B - 10	3GM-14107-17	C - 4	4TX-14900-00	C - 4	4NX-15462-01	C - 10
3LD-11134-10	B - 2	3LD-12168-K1	B - 6	4TX-12465-00	B - 10	4TX-1411A-00	C - 5	5AR-14900-00	C - 4	3VD-15463-00	C - 11
3LD-11160-02	B - 2	3LD-12168-M1	B - 6	1UF-12467-00	B - 10	3GM-1411E-00	C - 4	4TX-14901-00	C - 4	1JK-15486-00	C - 10
4TX-11166-01	C - 3	3LD-12168-R1	B - 6	4UN-12469-00	B - 9	2RJ-14118-00	C - 5	5AR-14901-00	C - 4	3LD-15512-00	C - 12
4NX-11181-00	B - 2	3LD-12168-U1	B - 6	3LD-12481-00	B - 9	3GM-14141-92	C - 5	4TX-14902-00	C - 4	4NX-15515-00	C - 12
3LD-11193-01	B - 2	3LD-12168-W1	B - 6	4NX-12481-00	B - 11	3GM-14141-93	C - 5	5AR-14902-00	C - 4	3LD-15517-00	C - 12
214-11198-01	B - 13	3LD-12168-Y1	B - 6	4NX-12482-00	B - 10	4G0-14142-42	C - 5	3LD-14919-00	C - 5	26H-15521-00	C - 12
4UN-11310-00	B - 3	3LD-12168-00	B - 6	1AA-12561-00	B - 10	4G0-14142-45	C - 5	4TX-14933-00	C - 4	3LD-15590-02	C - 12
3VD-11351-00	B - 3	3LD-12168-20	B - 6	4NX-12576-00	B - 11	1AE-14147-00	C - 4	3GM-14940-00	C - 4	4TX-16150-01	C - 13
3LD-11361-00	C - 8	3LD-12168-40	B - 6	4NX-12577-00	B - 11	3EN-14147-00	C - 5	3LD-14945-00	C - 4	3VD-16154-00	C - 13
4NX-11400-00	B - 4	3LD-12168-60	B - 6	4TX-12578-00	B - 10	3FV-14147-00	C - 4	4G0-14953-00	C - 5	4H7-16154-00	C - 13
3LD-11416-00	B - 4	3LD-12168-80	B - 6	4NX-12579-00	B - 11	3LD-14147-00	C - 4	3GM-14974-00	C - 6	3VD-16164-00	C - 13
3LD-11416-10	B - 4	3LD-12168-E0	B - 7	1UF-12611-00	B - 10	3LF-14147-00	C - 4	3GM-14985-00	C - 4	4NX-16181-00	C - 14
3LD-11416-20	B - 4	3LD-12169-G0	B - 7	26H-12630-00	B - 10	822-14147-00	C - 6	3LD-14986-00	C - 5	4TX-16321-00	C - 13
3LD-11416-30	B - 4	3LD-12169-J0	B - 7	3LD-13113-00	B - 13	4TX-14148-00	C - 6	4NX-14987-00	C - 6	3J2-16324-00	C - 13
3LD-11416-40	B - 4	3LD-12169-L0	B - 7	4TX-13132-00	B - 14	3GM-14153-00	C - 4	4TX-14987-00	C - 6	4UN-16340-00	C - 13
3LD-11416-50	B - 4	3LD-12169-N0	B - 7	3LD-13151-00	B - 13	239-14172-14	C - 5	3EN-14988-00	C - 6	3LD-16351-00	C - 13
3LD-11416-60	B - 4	3LD-12169-TO	B - 7	3LD-13161-00	B - 13	53L-14186-00	C - 4	3LD-14988-00	C - 6	3LD-1637A-01	C - 13
4NX-11500-00	B - 4	3LD-12169-11	B - 6	4TX-13266-00	B - 14	3FV-14191-00	C - 4	1KT-14994-00	C - 6	4TX-16371-00	C - 13
4NX-11510-00	B - 4	3LD-12169-31	B - 7	3LD-13300-00	B - 12	2LH-14197-00	C - 6	4TX-14995-00	C - 5	3LD-16382-00	C - 13
3LD-11583-00	B - 4	4NX-13303-00	B - 12	4NX-13303-00	B - 12	4HM-14216-00	C - 6	3EN-14997-00	C - 6	3LD-16398-00	C - 13
3LD-11584-00	B - 4	3VD-13317-00	B - 14	3VD-13317-00	B - 14	3LD-1423A-79	C - 5	3GM-14997-00	C - 4	3LD-17121-00	C - 15
3VD-11610-00	B - 4	3VD-13325-00	B - 12	3VD-13325-00	B - 12	820-14231-15	C - 5	3VD-15100-21	C - 8	4UN-17131-00	C - 15
3VD-11610-20	B - 4	3LD-12171-00	B - 8	3LD-13329-00	B - 12	830-14231-14	C - 5	3LD-15118-00	C - 9	2GH-17141-00	C - 15
3VD-11610-40	B - 4	3LD-12176-00	B - 8	3LD-13339-00	B - 12	4HM-14239-00	C - 6	2HY-15138-00	C - 8	2GH-17151-00	C - 15
4NX-11631-00	B - 4										

NUMERICAL INDEX

PARTNO.	GRID NO.	PARTNO.	GRID NO.	PARTNO.	GRID NO.	PARTNO.	GRID NO.	PARTNO.	GRID NO.	PARTNO.	GRID NO.
4TX-17211-00	C-15	3FY-21575-01	D-6	4TX-2311G-00	D-14	3VD-24181-00	E-2	4TX-25364-00	E-8	29L-25919-00	E-10
4UN-17231-00	C-15	4TX-2161A-00	D-7		D-15	4NO-24181-00	C-2	1AE-25366-00	E-8	3GM-25919-00	E-7
4NX-17241-00	C-15	3LD-21621-01	D-8	4TX-2311H-00	D-14	3Y6-24183-00	E-2	3AJ-25361-01	E-8	3HE-25924-00	E-7
4NX-17251-00	C-15	50M-21638-00	D-9		D-15	47X-24183-00	E-2	3HE-25388-00	E-8		E-10
4NX-17402-00	C-15	2MG-21639-00	D-6	4TX-23110-00	D-14	2GH-24184-00	E-2	29L-25398-00	E-6	3GM-25925-00	E-7
3VD-17411-00	C-15	2TV-21639-00	F-5	4TX-23115-00	D-14	12R-24188-00	E-2		E-8		E-10
4AS-17460-00	C-15	51Y-21639-00	D-9		D-15	47X-24186-00	E-2	29L-25398-10	E-6	3VD-26111-11	E-11
4NX-17471-00	D-2		D-10	4KM-23123-01	D-15	4TX-24191-00	E-2		E-8	4TX-26131-00	E-13
3LD-18101-02	D-4	3VD-2164F-00	D-11	4TX-23125-A0	D-14	4TX-24192-00	E-2	29L-25398-20	E-6	3FH-26240-00	E-11
3VD-18110-10	D-4	3VD-21645-00-P7	D-7		D-15	4TX-24240-30	E-2		E-8	1KG-26241-00	E-11
132-18113-01	D-4	3VD-21645-00-P9	D-7	4TX-23126-01	D-14	4TX-24240-40	E-2	4TX-25442-00	E-8	51J-26246-01	E-11
22N-18113-00	F-2	3VD-21645-00-4B	D-7	4TX-23135-A0	D-14	4TX-24240-60	E-2	3HE-2580T-70	E-7	4TX-26280-00	E-11
3VD-18115-00	D-4	4TX-21649-00	F-4	4TX-23136-01	D-14	4TX-24310-00	E-3	3HE-2580U-70	E-7	3XW-26281-01	E-11
4G0-18127-00	D-4	4TX-21651-00-P3	D-7	4TX-23141-00	D-14	4TX-24311-00	E-3	4TX-2580W-00	E-10	3XW-26282-01	E-11
3LD-18130-00	D-4	4TX-21651-00-P4	D-7		D-15	4TX-24315-00	E-3	4HM-2581T-01	E-7	3VD-26290-01	E-11
4NX-18140-00	D-3	4TX-21651-00-4B	D-7	4TX-23144-00	D-14	4TX-24326-00	E-3	3VD-25819-00	E-10	4TX-26292-00	E-11
2H9-18154-00	D-4	4TX-21652-01	D-10		D-15	1JK-24327-00	E-3	3LN-2582A-00	F-2	4TX-26302-00	E-11
4NX-18175-00	D-3	4TX-21711-00	D-9	4TX-23145-00	D-14	3LN-24500-00	E-3	3VD-2582E-02	F-2	4TX-26331-00	E-11
3VD-18511-00	D-3	15A-21717-00	F-5		D-15	4TX-24510-00	E-2	4HM-2582W-00	E-10	1VJ-26333-00	E-11
3VD-18512-00	D-3	4TX-21717-00	F-4	4TX-23151-00	D-14	4XB-24512-00	E-2	1FK-25827-00	E-10	4TX-26335-00	E-11
3VD-18513-00	D-3	4TX-21721-00	D-10		D-15	4TX-2452E-00	E-3	1FK-25828-00	E-10	4TX-2637G-00	D-13
4NX-18531-00	D-3	4TX-2173M-00	D-9	4TX-23156-00	D-14	3AJ-24523-00	E-3	3YX-2583H-00	E-12	3VD-27211-00	F-2
4NX-18535-00	D-3	4TX-21732-00	D-9		D-15	4DN-24523-00	E-2	4TX-2583V-00	F-2	3VD-27212-00	F-2
3LD-18536-00	D-3	4TX-21735-00	D-9	4TX-23157-00	D-14	3AJ-24534-00	E-2	1KT-25836-00	E-7	47X-27222-00	F-2
3VD-18540-01	D-3	11H-21747-00	D-5		D-15		E-3	42H-25836-00	E-10	3VD-27311-01	E-14
4UN-18542-00	D-3	3Y6-21747-00	D-9	4TX-23170-00	D-14	4FM-24602-00	E-3	3YX-25838-00	E-12	3VD-27315-00	E-14
4UN-18566-00	D-3	4TX-2177G-00	D-9		D-15	4BH-24705-00	E-5	341-25846-00	E-6	1TX-27351-00	E-14
4TX-21110-01-35	D-5	4TX-21781-30	D-6	4TX-23173-00	D-14	4TX-2471K-00-P3	D-6	3LN-2585F-00	F-2	1UA-27410-00	E-14
4TX-21161-00	D-5		D-7		D-15	4TX-2471K-00-P4	D-6	3LN-2585H-00	F-2	4TX-27412-00	E-15
3VD-21164-00	D-5	4TX-21781-40	D-6	4TX-2319K-00	D-14	4TX-2471K-00-4B	D-6	2KF-25852-50	F-2	2GH-27413-00	E-15
4TX-2117E-00	D-7		D-7		D-15	4TX-24718-00	E-5	4TX-25852-00	E-12	46X-27413-00	E-14
4KB-21268-00	D-5	4TX-21781-60	D-7	4TX-2331G-00	D-14	4TX-2472K-00-P3	D-7	3YX-25854-00	E-12	3VD-27414-00	E-14
	D-7	1AA-21815-00	D-9		D-15	4TX-2472K-00-P4	D-7	360-25854-01	F-2	1UA-27420-00	E-14
46X-21269-00	D-7	3VD-21816-00	D-9	4TX-2331L-00	D-14	4TX-2472K-00-4B	D-7	2GU-25855-00	F-2	4TX-27422-00	E-15
4TX-2135F-01	D-5	3VD-21871-00	D-9		D-15	509-24724-00	E-5	3YX-25866-00	E-12	1NL-27424-00	E-14
3VD-21366-00	D-6	1AA-21874-00	D-9	3VD-23317-00	E-13	4TX-24728-00	E-5	3YX-25866-10	E-12	38Y-27424-00	E-15
4TX-21376-00	E-5	4TX-22110-00	D-11	4TX-23340-00	D-15	4TX-24730-01	E-5	3YX-25887-00	E-12	4BR-27431-00	E-14
3VD-2139X-00	E-15	4X7-22129-00	D-11	4TX-23377-00	F-15	4TX-24731-00	E-5	4TX-25871-00	E-12	2YK-27434-01	D-4
30X-2139X-00	E-3	46X-22141-00	D-11	4TX-23378-00	F-15	22W-24741-00	E-5	3VD-25872-51	F-2	1HX-27437-00	E-14
	F-5	3VD-22151-00	D-11	4TX-23389-00	D-13	4TX-24748-00	E-5	4TX-25872-00	E-12	4BR-27441-00	E-14
3VD-21411-10-35	D-5	3HE-22174-00	E-8	1W1-23416-00	D-13	4TX-24776-01	E-5	4TX-25874-00	E-12	3VD-27442-11	E-14
4TX-21419-00-35	D-5	33M-22184-00	D-11	26H-23418-01	D-13	4TX-2478F-00	E-5	3VD-25875-01	D-11	3VD-27443-11	E-14
3LD-2143A-00	D-5	4TX-22210-00	D-12	4TX-23435-00	D-13	47X-24796-00	E-5	4TX-25875-00	E-13	4TX-28100-00	D-8
3VD-2143A-00	D-5	3VD-22216-00	D-12	4H7-23441-00-PO	D-13	341-25149-00	E-6	3YX-25880-00	E-12	4TX-28321-00	F-5
4TX-2148U-00	D-5	3VD-22311-00	D-11	3FV-23462-00	D-13	3VD-25168-00-7B	E-6	3LC-25885-00	F-3	4TX-28322-00	F-5
3VD-21489-00	D-5	3VD-22464-00	D-12	4TX-24110-10-05	E-2	4TX-24110-10-07	E-2	3YX-2589F-00	E-12	4TX-28328-30	F-4
4X7-2149Y-00	E-4	4TX-23102-01	D-14	4TX-24110-10-08	E-2	4TX-25190-10	E-6	47X-25894-00	F-2	5AR-28328-00	F-4
3GM-21512-00	D-6	4TX-23103-01	D-14		E-2	3VD-25338-00-7B	E-8	3VD-25895-01	F-2	5AR-28328-20	F-5

NUMERICAL INDEX

PARTNO.	GRID NO.	PARTNO.	GRID NO.	PARTNO.	GRID NO.	PARTNO.	GRID NO.	PARTNO.	GRID NO.	PARTNO.	GRID NO.
4TX-28338-30	F-5	4TX-82509-00	F-14	3YX-83945-00	F-13	90105-10560	C-8	90167-05076	F-4	90201-10669	E-15
5AR-28338-00	F-5	4TX-82530-00	F-14	4TX-83969-00	F-13	90105-10638	E-7		F-10	90201-11597	C-8
5AR-28338-20	F-5	4TX-82539-00	F-14	4TX-83975-00	F-13		E-10	90170-06228	D-4	90201-121H0	B-5
4TX-28345-00	F-4	4TX-82540-00	F-15	4BH-83980-00	E-12	90105-12584	B-5	90170-20327	C-13	90201-12163	C-13
4TX-2835G-00-0X	F-4	3LN-82560-01	F-15	4TX-84163-00	F-11	90109-062G1	B-2	90176-22081	D-13	90201-124G9	D-12
4TX-2835G-00-2X	F-4	3LD-82566-50	F-15	3GM-84192-10	F-11	90109-062G2	B-2	90179-05523	F-4	90201-12575	D-4
4TX-2835G-00-4X	F-4	4TX-82590-20	F-14	3GM-84301-00	F-11	90109-064F0	B-2		F-5	90201-127E1	B-9
4TX-2835U-00-4B	F-4	1UA-82591-00	E-12	4TX-8431R-00	F-11	90109-080G5	F-14	90179-06500	F-4	90201-150U6	C-13
4TX-2835U-00-95	F-4	3YX-82911-00	F-13	4TX-84320-00	F-11	90109-083E2	E-14	90179-06635	E-5	90201-160T2	E-9
4TX-2835V-00-4B	F-5	3YX-82917-00	F-13	4TX-84320-10	F-11	90109-083G1	D-5	90179-08148	F-13	90201-161J3	D-11
4TX-2835V-00-95	F-5	3GM-83310-00	F-8	3GM-84321-00	F-11	90109-083G4	E-7	90179-08345	C-7	90201-170T3	E-8
4TX-28356-00	F-4	306-83311-40	F-8	3GM-84322-00	F-11		E-10	90179-09379	B-4	90201-191J4	D-4
4TX-2836K-00	F-4	3GM-83320-00	F-8	3GM-84340-40	F-11	90109-085E2	D-7	90179-10247	E-14	90201-200K3	C-15
4TX-2837N-00	F-5	3VD-83330-00	F-8	3TJ-84311-00	F-11	90109-086A0	E-2	90179-10377	D-5	90201-20278	D-2
4TX-2837R-00	F-5	1VU-83332-00	F-8	4TX-84359-00	F-11	90109-104E6	E-14	90179-10414	B-2	90201-22070	D-13
4KM-28371-00	F-4	51L-83332-01	F-8	3GM-84367-50	F-11	90109-125F1	D-12	90179-18667	D-2	90201-301P3	C-12
4TX-28381-00	F-4	3VD-83340-00	F-8	3GM-84397-40	F-11	90110-05112	E-3	90179-25033	D-13	90202-05193	E-2
4TX-28391-30	F-5	1VU-83342-00	F-8	4TX-84710-00	F-12	90110-05201	F-5	90183-05024	B-10	90202-05224	F-5
4TX-28391-40	F-5	51L-83342-01	F-8	31L-84714-00	F-12	90110-06093	B-14		D-7	90202-24190	D-13
4TX-28391-60	F-5	3GM-83350-01	F-15	4TX-84723-00	F-12	90110-08071	E-14		F-5	90202-26142	D-13
4TX-28392-30	F-5	4NX-83354-00	F-15	4TX-84733-00	F-12	90110-08199	E-15	90183-05042	F-4	90206-12074	D-4
4TX-28392-40	F-5	10V-83365-00	D-12	4G1-84744-00	F-9	90110-10229	D-5	90183-06023	D-6	90209-05279	C-10
4TX-28392-60	F-5		F-8	4TX-84751-00	F-12	90116-08548	B-2	90183-06053	D-9	90209-08295	E-14
4TX-81410-00	F-7	18G-83365-00	F-8	3G1-85130-01	F-12	90116-10485	E-8	90185-10037	E-14	90209-11262	B-2
4TX-81450-00	F-7	4KM-83371-00	F-15	3Y6-85130-02	F-12	90119-06044	D-11	90185-14112	D-11	90209-21332	C-15
3LD-81800-00	C-12	4TX-83509-00	F-9	4KM-85130-00	F-12	90119-06056	D-9	90201-04018	D-6	90209-28330	C-15
3AJ-81801-00	C-12	4TX-83513-00	F-9	3HE-85132-01	D-6	90119-06108	D-11	90201-047A2	D-8	90209-28331	C-15
3AJ-81809-00	C-12	1YT-83517-00	F-9	47G-85353-00	F-11	90123-08096	F-13	90201-052E8	F-4	90209-29329	C-15
3LD-81815-00	C-12	4R0-83517-00	F-9	4HM-85885-10	C-6	90149-04278	D-8	90201-054K4	F-11	90215-20231	C-13
3AJ-81826-00	C-12	42X-83517-00	F-9	90101-06278	F-2	90149-05299	F-5	90201-06045	C-11	90215-21290	C-15
3AJ-81830-00	C-12	4FM-83520-00	F-9	90101-06576	C-7	90149-06011	E-2	90201-06057	F-12	90240-08013	F-2
11H-81844-00	C-12	4TX-83523-01	F-9	90101-10659	D-12	90149-06285	C-9	90201-06063	C-3	90267-32071	D-6
1FK-81847-00	C-12	4SV-83526-00	F-9	90105-06131	C-11	90149-06286	C-15	90201-06071	B-10	90267-40036	D-6
4G0-81871-00	C-12	4TX-8353B-00	F-9	90105-06153	B-2	90150-05024	F-4		D-9	90267-40073	D-6
4DN-81940-00	F-15	4TX-8353H-00	F-9	90105-06397	D-3	90153-06029	B-3		F-12	90267-40105	D-11
4EP-81950-00	F-15	4TX-83540-00	F-9	90105-06446	D-5	90157-05079	E-14	90201-06380	F-10	90280-05029	B-5
4JH-81960-01	F-14	3XP-83550-01	F-10	90105-06456	B-13		E-15	90201-066F0	C-8	90338-05194	C-2
1Y8-81970-60	F-11	4TX-83559-00	F-9		C-10		F-15		C-9	90338-08163	D-13
4TX-82100-01	F-14	4TX-83570-00	F-9	90105-06477	D-6	90159-03102	F-9	90201-08083	F-2	90338-08174	E-4
116-82131-00	D-8	4TX-83570-10	F-9	90105-06553	B-13	90159-06056	F-2	90201-08087	C-8	90338-10132	F-5
133-82131-00	D-8	4TX-83578-00	F-9		B-14	90159-06059	D-10	90201-08326	C-7	90338-10150	B-2
1AE-82151-00	F-15	4TX-83590-00	F-9	90105-06556	D-13	90159-06093	D-9		D-4	90338-11257	C-8
2KW-82151-00	F-14	11H-83591-00	F-15	90105-06557	D-3	90159-06123	C-13	90201-10118	E-12	90338-12192	D-6
36Y-82151-00	F-14	4TX-83611-00	F-9	90105-06597	D-3	90164-04008	F-9		F-3	90340-14132	B-13
4TX-82305-00	F-14	3YX-83912-00	F-13	90105-07342	B-8	90167-03058	F-9	90201-10119	C-13	90340-14151	C-11
3TB-82310-00	F-14	3YX-83922-00	E-12	90105-08752	D-5	90167-04057	F-9	90201-103M4	B-2	90340-18101	B-2
3LD-82370-00	F-14	25G-83936-01	F-15	90105-10271	C-7	90167-05025	F-11	90201-10430	D-5	90340-32116	C-11
4JH-82501-03	F-14	437-83936-01	F-13	90105-10328	D-5	90167-05037	F-11	90201-10437	E-10	90380-20213	E-15

NUMERICAL INDEX

PARTNO.	GRID NO.	PARTNO.	GRID NO.	PARTNO.	GRID NO.	PARTNO.	GRID NO.	PARTNO.	GRID NO.	PARTNO.	GRID NO.
90384-18190	D-12	90450-32015	B-14	90480-01603	D-10	91317-08110	C-7	93210-16629	B-14	94701-00242	B-2
90387-052U5	F-11	90450-32051	B-11	90480-10258	D-6	91317-10025	D-14	93210-18N01	D-14	95024-06012	B-9
90387-064H8	E-15		B-14	90480-10517	F-11		D-15		D-15	95024-06020	B-9
90387-064J1	D-6	90450-38040	B-10	90480-12550	D-7	91317-10030	D-15	93210-18417	B-11		B-12
	D-11		B-14	90480-13369	D-9	91401-20012	F-2	93210-21190	B-9		C-9
90387-065T2	D-6	90450-57034	C-2	90480-13426	F-4	92014-06010	F-14	93210-26741	B-14	95024-06025	B-13
90387-06605	E-2	90450-67066	C-2	90480-14229	F-4	92014-08020	F-2	93210-27370	B-14		C-10
90387-06681	D-11	90480-27270	B-14	90480-14555	F-10	92017-06012	D-7	93210-29196	F-15		E-12
90387-06761	B-15	90481-10136	C-11	90480-14604	C-2	92017-06035	E-2	93210-30660	B-5	95024-06030	B-9
90387-0700G	B-10	90482-20223	C-11	90480-15363	B-10	92906-04600	E-12	93210-32172	C-11		B-12
90387-07390	B-10	90464-05188	F-6	90480-16233	D-9	92907-03100	F-9	93210-33133	B-9		C-10
90387-07391	C-2	90464-10075	E-3	90480-16404	D-9	92907-04100	F-9		D-2	95024-06035	C-11
	F-10	90464-10190	D-9	90480-18276	F-12	92907-04600	B-2	93210-34504	D-14	95024-06040	B-12
90387-07674	D-9		F-15	90501-08022	D-3		F-9		D-15	95024-06045	B-9
90387-077M3	F-12	90464-12238	C-6	90501-104F9	B-13		F-15	93210-36788	B-9		C-11
90387-065N0	B-15	90464-13073	F-15	90501-12743	E-14	92907-05100	C-4	93210-44545	C-2		E-15
90387-0910H	F-6	90464-13077	F-12	90501-225A9	C-13	92907-05600	B-10	93210-49046	B-11	95024-06055	C-10
90387-104L8	E-15	90464-15192	F-6	90506-18224	E-14		C-2	93210-64297	B-12		C-11
90387-106W6	B-13		F-15	90506-20192	F-2		C-4	93210-90785	B-3	95024-06060	B-9
	B-15	90464-20191	F-6	90506-26225	E-14		C-5	93306-20314	E-8	95024-06110	C-11
90387-120W5	B-12		F-15	90508-167A3	C-13	92907-06100	F-2	93306-20455	D-2	95024-08012	B-2
90387-127X0	D-12	90464-25217	F-6	90508-297A4	D-3	92907-06600	D-11	93306-20464	C-15	95024-10040	B-13
90387-130W6	B-15		F-15	90508-32682	D-4		F-7	93306-30309	E-8	95026-06030	E-12
90387-173M5	E-8	90465-08122	C-10	90560-07007	D-9	92907-08100	F-14	93306-30319	E-6	95027-06010	D-6
90387-177K0	E-8	90465-08127	C-10	90560-17233	E-6	92907-08200	C-5	93306-30525	C-15		E-3
90387-177R1	E-6	90465-08341	C-9	91314-06020	B-14	92907-08600	E-8	93306-37207	E-8	95027-06012	E-11
90387-177Y4	E-9	90465-08380	F-7	91314-06025	B-8	92907-08600	C-13	93310-365B8	C-14	95027-06014	B-11
90387-177Y5	E-9	90465-15384	C-10		B-14	92990-05600	B-10	93315-11206	C-13		F-12
90387-203M7	C-15	90465-20035	C-2	91314-08016	C-8	92990-06600	C-7	93317-11020	C-13	95027-06016	B-9
90387-22660	E-11	90465-20342	C-11	91314-08030	D-13	93101-12004	D-4	93317-21236	C-10		B-15
90387-253M6	C-15	90467-07029	C-6	91314-10025	D-5	93102-12224	C-13	93320-32403	D-11	95027-06020	B-11
90387-2802W	C-15	90467-07093	C-6	91314-10045	D-5	93102-25044	E-8	93340-21505	C-13		B-12
90401-10106	B-13	90467-08017	C-2	91314-10060	D-5	93102-28022	E-6	93399-99931	D-13		D-6
90401-10159	E-12		E-3	91317-05010	E-3	93102-35459	C-15	93399-99932	D-13		F-13
	F-3	90467-08075	C-2	91317-05016	F-7	93105-42024	E-8	93440-10109	B-2	95027-06025	B-11
90430-06014	B-3		D-9		F-14	93105-45017	E-6	93440-25084	C-15		B-12
	B-9		E-3	91317-06010	F-15	93109-12053	C-10	93440-31172	C-15		B-13
90430-08119	B-2	90467-09006	E-3	91317-06014	F-15	93109-18020	D-12	93440-45144	D-2		C-10
90430-10171	D-14	90467-10008	E-3	91317-06018	B-11	93210-07135	B-15	93450-22027	B-4	95027-06030	B-12
	D-15	90467-10041	E-4	91317-06018	C-12	93210-10096	B-13	93501-04011	E-14	95027-06035	B-13
90430-10188	B-13	90467-10135	E-4	91317-06020	B-14		B-15	93505-08030	B-13		C-11
90430-14131	B-12	90467-11106	E-3		C-2	93210-12095	C-8	93900-00030	E-6	95027-06040	B-12
90445-086J6	D-9		E-4	91317-06025	B-14	93210-12790	B-13		E-8	95027-06045	C-11
90445-090E5	C-2	90467-12052	C-6		D-9		B-15	94111-1810C	E-6	95027-06055	C-11
90445-106J2	E-3	90467-14057	F-2	91317-06150	B-2	93210-13657	B-13	94115-1710D	E-8	95027-06110	C-11
90445-11153	E-4	90467-22080	C-3	91317-06160	C-11		B-14	94581-46114	E-8	95027-08025	C-7
90445-112E1	E-4	90467-24113	C-3	91317-08016	C-8	93210-14369	C-11	94591-40138	B-8	95027-10040	B-13
90450-32015	B-11	90480-01558	F-6	91317-08040	D-15	93210-15566	B-15	94701-00241	B-2	95301-06600	E-12

NUMERICAL INDEX

PARTNO.	GRID NO.	PARTNO.	GRID NO.	PARTNO.	GRID NO.	PARTNO.	GRID NO.	PARTNO.	GRID NO.
95304-06700	D- 4	95817-08075	C- 9	98907-06012	F- 14				
95307-05600	C- 5	95817-08080	F- 4	99001-07800	C- 13				
95307-06600	C- 8	95827-06012	D- 2	99001-10600	D- 4				
	F- 10	95827-06020	D- 4	99009-10400	C- 13				
	F- 12	95827-08040	D- 7	99009-11400	B- 12				
95307-08600	E- 8	95827-10030	E- 10	99009-12400	B- 9				
95307-08700	F- 2	95880-06035	C- 11	99009-19400	D- 4				
95307-12600	F- 8	97007-05012	B- 10	99224-00140	E- 2				
95307-12700	F- 8	97007-06025	C- 3	99228-00140	E- 2				
95604-06200	E- 15		D- 11	99234-00080	D- 7				
95604-16200	E- 9	97007-08030	E- 2	99236-00080	D- 7				
95606-06100	E- 12	97706-40620	F- 8		F- 4				
95607-04100	D- 8		F- 12	99237-00080	F- 4				
95607-06100	F- 12	97707-40010	F- 4	99510-08016	B- 2				
	F- 13	97707-40620	F- 8	99530-08012	B- 12				
95607-06200	E- 3	97707-50012	D- 7		C- 9				
95607-10200	E- 8		F- 5		C- 10				
95607-12100	D- 12	97707-50125	C- 2		C- 11				
95617-10100	D- 12	98501-05012	C- 4	99530-08016	B- 13				
95707-05500	E- 5	98506-04014	E- 12		C- 9				
	F- 12	98507-03008	E- 2	99530-10114	C- 8				
95707-10500	C- 7	98507-03010	F- 9		C- 11				
95807-06010	D- 5	98507-04006	B- 2	99530-14016	B- 3				
	F- 2	98507-04008	C- 4		C- 8				
	F- 15		F- 15						
95807-06012	F- 6	98507-04010	F- 9						
95807-06020	F- 11	98507-05008	B- 10						
	F- 14	98507-05010	B- 10						
95807-06025	B- 10		C- 10						
95814-06040	C- 8	98507-05016	C- 2						
	C- 9		C- 4						
95814-08050	C- 8	98507-05022	F- 13						
	C- 9	98507-05030	F- 13						
95814-08060	C- 8	98507-05035	E- 11						
95817-06020	C- 8	98507-05040	F- 13						
95817-06025	C- 9	98507-06008	F- 14						
95817-06030	C- 8		F- 15						
95817-06040	C- 8	98507-06010	B- 12						
	C- 9	98507-06016	F- 14						
	C- 9		F- 15						
95817-06045	C- 9	98507-06035	B- 12						
95817-06050	C- 12		F- 7						
95817-06055	C- 8	98507-06045	B- 12						
95817-06070	C- 8	98706-04012	E- 12						
	C- 9	98707-03020	F- 13						
95817-08035	F- 4	98707-04008	C- 5						
95817-08050	C- 9	98707-05012	D- 3						
95817-08065	C- 8	98907-05010	D- 7						
95817-08070	C- 9								

*COPYRIGHT : All rights reserved. No part of this publication
may be reproduced without permission.*

YAMAHA

YAMAHA MOTOR CO., LTD.
2500 SHINGAI IWATA SHIZUOKA JAPAN
SERVICE INFORMATION DIV.

PRINTED ON RECYCLED PAPER

Printed in Japan
First edition AUG., 1997